

RESTRICTED

TM 11-235

WAR DEPARTMENT

TECHNICAL MANUAL

**RADIO SETS SCR-536-A, SCR-536-B,
AND SCR-536-C**

May 14, 1943

Note.—This is not a revision. This manual contains only C 1, 15 December 1943, to the 14 May 1943 edition placed at the back following the original text, and will not be loaned to individuals possessing that edition.

RESTRICTED

TECHNICAL MANUAL }
 No. 11-235 }

WAR DEPARTMENT,
 WASHINGTON, MAY 14, 1943.

RADIO SETS SCR-536-A, SCR-536-B, AND SCR-536-C**DESTRUCTION NOTICE**

Depending upon the time and materials available, when the capture of this equipment by the enemy is certain, completely destroy it by one or more of the following means:

1. Explosives such as grenades or TNT.
2. Incendiaries such as wood, oil, and gasoline.
3. Axes, hammers, large rocks, or other hard, heavy objects such as hand generators, dynamotors, etc.

Removal of the chassis from the case will simplify the above means of destruction. When this is done be sure to smash crystals and holders, tubes, coils, microphone, earphone, and batteries.

Destroy all instruction books, Technical Manuals, circuit diagrams, or other literature for this radio set at the same time.

SAFETY NOTICE

The voltages used in this radio set are not high enough to be injurious. A slight shock, of negligible magnitude, may result by touching the antenna and case at the same time, when the set is transmitting.

	Paragraphs
SECTION I. Description.....	1-9
II. Employment.....	10-23
III. Functioning of parts.....	24-38
IV. Maintenance.....	39-78
V. Supplementary data.....	79-80
INDEX	Page 82

*This manual supersedes TM 11-235, March, 1942.

SECTION I

DESCRIPTION

	Paragraph
Use.....	1
Components, weights, and dimensions.....	2
Total weights.....	3
Source of power and power requirements.....	4
Distance range.....	5
Frequency coverage.....	6
Modes of transmission and reception.....	7
Controls.....	8
Description of components.....	9

1. Use.—Radio set SCR-536-(*) is designed for short-range two-way voice conversation. Descriptively, it is a press-to-talk portable radio telephone, receiving and transmitting on the same frequency. No skill is required to operate it.

a. The set is self-contained; all equipment necessary for reception and transmission is contained in one aluminum case.

b. The set may be held in either hand when operating, although it is designed and balanced for left-hand operation. The microphone and earphone are attached to the case in such manner that the set resembles a hand telephone. An adjustable carrying strap is attached to the case. (See figs. 1 and 2.)

Radio sets SCR-536-A, SCR-536-B, and SCR-536-C are alike, for all practical purposes. The different suffix letters indicate different procurements. For convenience, they are referred to throughout this manual as radio set SCR-536-() except where some difference exists between types. Similarly the component parts, radio receivers and transmitters BC-611-A, BC-611-B, and BC-611-C are referred to as radio receiver and transmitter BC-611-(*). Test equipments IE-17-A, IE-17-B, and IE-17-C are referred to as IE-17-(*).

2. COMPONENTS, WEIGHTS, AND DIMENSIONS.

Quantity	Article	Dimensions (inches) ¹					Unit weight (pounds)
		Height	Width	Depth	Length	Diameter	
1	Battery BA-37 (1.5 volts).....	6 $\frac{1}{2}$				1 $\frac{1}{16}$	0.55
1	Battery BA-38 (103.5 volts).....	11 $\frac{3}{4}$	1 $\frac{11}{32}$	1 $\frac{11}{32}$			1.10
2	Preliminary instructions.....	11	8 $\frac{1}{2}$				
1	Radio receiver and transmitter BC-611-(*) (with coils, crystals and tubes, but without batteries).	15 $\frac{3}{4}$	3 $\frac{3}{8}$	5 $\frac{1}{4}$			3.85
1	Set of crystals (spare). ²						
1	Tube set GK-174 (spare): Consisting of:						
	1 tube VT-171.....						.01
	1 tube VT-172.....						.01
	1 tube VT-173.....						.01
	2 tube VT-174.....						.01
1	Box BX-49 Containing: ³ 12 sets of crystals (transmitting and receiving) 12 sets of antenna coils. 12 sets of r-f tank coils. (1 set of coils and crystal for each of 12 operating frequencies).						

¹ Dimensions, where unappreciable, are omitted.

² Component of SCR-536-A only.

³ Component of SCR-536-C only.

3. Total weights.—Total weight of radio set SCR-536-(*) including batteries, is 5.5 pounds. Over-all dimensions and weights of components are given in paragraph 2.

4. Source of power and power requirements.—Radio receiver and transmitter BC-611-(*) is battery powered. Space for both A and B batteries is provided in the housing. (See fig. 1.)

a. The filament or A battery BA-37, rated at 1.5 volts, is cylindrical in shape and fits into the round compartment in the housing.

b. The B battery BA-38, rated at 103.5 volts, is oblong in shape and fits into the oblong compartment in the housing. (The bottom of the case has a hinged cover which permits access to the batteries and radio chassis.)

c. Power requirements.—Batteries should last 15 hours, under almost continuous operation.

Battery	Draw receiving	Draw transmitting
A battery BA-37 1.5 volts.....	0.25 amperes.....	0.30 amperes.
B battery BA-38 103.5 volts.....	11 milliamperes.....	35 milliamperes.

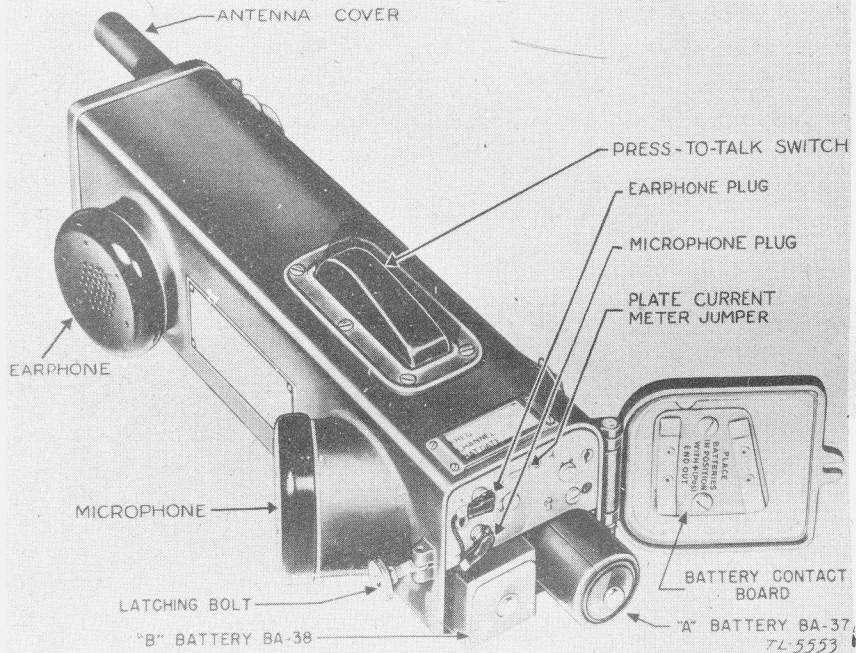

FIGURE 1.—Radio set SCR-536-(*)—showing battery compartment.

5. Distance range.—The set is designed to operate over distances from 100 feet to 1 mile. The dependability of operation at the greater distance will depend on the terrain and the freedom from signal absorbing objects such as steel buildings, trees, hills, and telephone and power lines between the two sets. This is particularly true for sets operating at the higher frequencies in the band. The maximum range may be considerably greater when operating over water or in the air.

6. Frequency coverage.—Radio set SCR-536-(*) is crystal controlled on both reception and transmission, and will operate over the frequency range of 3500 to 6000 kilocycles. However, each unit is adjusted to operate at only one frequency in this band. The set can be made to operate at any frequency in the band by proper choice of crystals and coils. For correct performance, each set must be adjusted to the crystals used. The coils and crystal changes and their adjustments cannot be made by the operator, but are preset by the manufacturer or by maintenance men at authorized repair points. (See sec. IV.)

7. Modes of transmission and reception.—Radio set SCR-536-(*) transmits and receives amplitude modulated voice signals only.

8. Controls.—*a. Send-receive.*—A press-to-talk switch, conveniently located under the finger tips when the radio set is held in normal operating position, is the only control required for operation of this equipment. (See fig. 1.)

b. On-off.—By fully extending the telescopic antenna rod, the set is automatically turned on. When the telescopic antenna rod is fully retracted the set is automatically turned off. (The bottom section of the antenna operates the on-off power switch.)

c. Volume.—No volume control is used with this set. The volume in the earphone is set to a normal level by the design of the equipment.

d. Tuning.—The operator is not required to make tuning adjustments of any kind. (See par. 6.)

9. Description of components.—*a.* The housing which incloses radio receiver and transmitter BC-611-(*) is an aluminum casting. Its interior is divided into three compartments, one for the radio chassis, one for the A battery BA-37, and one for the B battery BA-38. Two projections from the housing contain the earphone and microphone units. These projections are so spaced and of such length that when the unit is held with the earphone against the ear of the operator, the microphone or mouthpiece is in the proper position for talking.

b. The press-to-talk switch, mounted on the side of the case, operates the change-over switch on the radio chassis. This converts the set from a receiver to a transmitter. This switch is so located that it may be operated easily with the fingertips when the set is held in the left hand.

c. The bottom cover hinges to the housing and is provided with a slot into which a latching bolt fits. It is through this end of the housing that the chassis and batteries are inserted or removed. A contact terminal board inside the bottom cover provides the connections between the batteries and the radio chassis.

d. A small card holder below the press-to-talk switch contains a plastic card on which the operating frequency and date of battery replacement are marked. This card is protected from wear by a transparent cover. To remove the card from its container the bottom cover must be opened. (See fig. 1.)

e. The top cover of the set contains an opening for the antenna rod. This cover is held in place by a mounting screw which holds

the chassis securely in the housing. Spring battery contacts and a spacer for the A battery BA-37, fastened to the top cover, make electrical connections to the batteries.

f. An antenna cap, attached to the top cover on the outside by a chain, protects the telescopic rod antenna against weather conditions when the set is not in use.

NOTE.—Early issues of radio set SCR-536-A were furnished with a crystal microphone and crystal earphone. All later issues of SCR-536-A and radio sets SCR-536-B and SCR-536-C are furnished with an inductor microphone and an inductor earphone. These components are electrically and mechanically interchangeable with the crystal units they replace.

SECTION II

EMPLOYMENT

	Paragraph
Initial procedure.....	10
Installation.....	11
Preparation for use.....	12
Starting the set.....	13
Receiving.....	14
Transmitting.....	15
Turning off set.....	16
Operation over long periods.....	17
Netting.....	18
Change of frequency.....	19
Power output.....	20
Replacing batteries.....	21
Operation in the rain.....	22
Poor reception and transmission.....	23

10. Initial procedure.—Unpack the equipment carefully to prevent damage or loss of components. Check against list of components in paragraph 2. Also note the channel on which the radio receiver and transmitter are aligned.

11. Installation.—*a. General.*—The set is furnished by the manufacturer with everything contained in the housing except the batteries. To put the set into operation, the batteries must be inserted in their proper place.

b. Installation of batteries BA-37 and BA-33.—Open the radio set bottom cover by turning the latching bolt knurled nut in a counterclockwise direction, until the nut begins to turn with difficulty. Then press the cover against the case and push the bolt away from the housing. Release the cover and it will open. (See fig. 1.)

(1) Battery BA-37 (filament or A battery) is cylindrical in shape and fits into the round compartment of the radio set housing. Insert the battery into the housing with its positive end out. The

positive terminal is marked with a large positive (+) sign. It can be identified also by a small raised metal button. The raised button permits positive identification when installing battery in darkness.

(2) Battery BA-38 (B battery) is oblong in shape and fits into the oblong compartment of the radio set housing. It also must be placed into the battery compartment with the positive (+) end out. The positive terminal is marked with a large plus (+) sign and also can be identified by the small raised metal button.

NOTE.—Before closing the radio set bottom cover, mark the date of battery installation on the data card located in the pocket just below the press-to-talk switch. The card is removed by sliding it out of the bottom of the pocket. The transparent protective cover will come out with the card. Erase the old date that is marked on the card, and put on the new one. When replacing the card, remember to put the transparent protective cover over the card.

(3) After the batteries are installed close the bottom cover of the radio set by pressing the cover against the housing with one hand, while the other hand moves the latching bolt into the cover slot and tightens the knurled nut by turning it clockwise. The cover then should be pressed against a solid object and the knurled nut tightened by hand until it turns with great difficulty. This will assure positive contact between batteries and battery contacts. •

12. Preparation for use.—Before radio receiver and transmitter BC-611-(*) can be placed in operation, the following must be done:

a. Unscrew the antenna cap which covers the telescopic antenna. (See fig. 1.) To prevent losing it, this cap is attached to the housing by a small chain. Screw the cap on the threaded metal stud on top of the housing. This will prevent the cap from rattling against the housing when operating the set. See that the chain is *not* wrapped around the antenna rod and that there is no chance of it touching the rod.

b. Pull the antenna out gently until all four sections of the rod are fully extended. The antenna then will be about 39 inches long.

c. The unit is now held in the left hand, in the same manner as a telephone handset, and is ready for use as a radiotelephone set. (See fig. 2.)

13. Starting the set.—In succeeding paragraphs radio set SCR-536-(*) will be referred to as "the set." The set is turned on when the antenna is fully extended. This is accomplished by a small lever attached to the antenna rod which operates the power switch on the radio chassis. A rushing noise in the earphone will indicate that the receiver is on. Also a click will be heard when the switch tumbler snaps over.

Caution.—A stop at the lower end of the antenna rod prevents it from being pulled out of the case, but the bottom section of the antenna must be fully extended since it operates the power switch on the chassis **BY WHICH THE SET IS TURNED ON.**



FIGURE 2. Radio set SUR-536 (*) in operating position.

14. Receiving.—The set is normally in the receive position so that the operator can hear signals from another set if it is transmitting on the same frequency. The set should be held in the hand as shown in figure 2. The antenna will then extend above the head in an approximately vertical position. This is important for best reception and transmission.

15. Transmitting.—*a.* In order to transmit, the press-to-talk switch on the side of the housing must be depressed. This is done with the fingers of the hand holding the unit. The operator then can speak to the operator of the other set. The press-to-talk switch makes the necessary circuit changes to convert the receiver into a transmitter.

b. In order to receive, the press-to-talk switch must be released when transmission is completed.

c. When the operator is speaking into the microphone, the speech level should be varied according to distance of transmission. It should be very soft for short distances. The operator should speak clearly, and should take care that the press-to-talk switch is depressed *before* starting to speak, and is released immediately upon completion of conversation. In the beginning, the operator may experience some difficulty in synchronizing the operation of the press-to-talk switch with the beginning and end of his speech. There is a natural tendency to hold the switch down when through speaking, and to forget to press the switch before starting to speak. A little practice will eliminate this difficulty. It is good practice to pause for a moment after pressing the press-to-talk switch.

16. Turning off set.—Telescope the antenna into the case. The bottom section of the antenna rod must be pushed into the case *as far as it will go*. This will turn off the set. The operator can hear the toggle switch snap over. Put the antenna cap in place, covering the antenna when the set is not in use.

17. Operation over long periods.—When operating the set for long periods, it will be found less tiring to carry the set slung over the shoulder rather than to carry it in the hand. To carry it in this manner, lengthen the strap by pulling the strap slide toward the antenna end of the case. The reverse action will tighten it. Place the left arm between the strap and the set housing so that the set rests on the left shoulder. The set is slung to the front of the operator. The set then can be held there with a slight pressure from the arm, or by permitting it to rest in the crook of the arm. The sound caused by one station calling another will be loud enough to be heard, even though the earphone is several inches from the ear. The unit then can be brought into position for use.

18. Netting.—For two-way conversation, two sets adjusted to operate on the same frequency are required. Two sets operating at different frequencies will be unable to converse with each other. More than two operators can engage in conversation by the use of more sets operating on the same frequency. Because of the receiver arrangement used, it is possible to operate several receivers without interference at the same frequency and in close proximity. However, more than one radio set transmitting at the same time on the same frequency is likely to cause confusion in orders. Radio set SCR-536-(*) also can be used for voice communication with other types of radio sets adjusted to exactly the same frequency.

19. Change of frequency.—Changing the operating frequency of the unit requires a change of the two crystals and of two coils. Coil and crystal equipment is available to cover the frequency range of 3.5 megacycles to 6 megacycles if required. Special equipment is required for retuning of the sets, and a trained technician must do the job. The frequency presetting and realinement procedure will be found in section IV of this book.

20. Power output.—Maximum power output is obtained in the transmitting position with the antenna fully extended. If the units are not at a great distance from each other and a reduction of the power radiated is desired, telescope one or two of the top sections of the antenna. *The bottom section must remain fully extended.*

21. Replacing batteries.—See procedure given in paragraph 11a. *Replace both batteries even though one is in better condition than the other. This will reduce the chances of battery trouble.*

NOTE.—When sets are to be placed in storage for long periods of time, remove the batteries from the case. This will prevent the batteries from becoming wedged in the battery compartment, should they swell when aging.

22. Operation in the rain.—The set is designed to exclude water, but, if operated in the rain, it may be found that the water film covering the antenna insulator at the base of the antenna acts as a short circuit between the antenna and case, making the set weak or inoperative. Wipe the insulator frequently with a dry cloth to improve operation.

23. Poor reception and transmission.—*a.* If the distance between sets in communication with each other is between 100 feet and 1 mile, and the transmission is poor, it may be that the batteries are weak. The batteries are designed to give about 15 hours of use, assuming that the unit is on for long periods of time and that the operator is transmitting much of the time. They will last much longer if not used constantly. A sign of weak batteries is a low noise level in the earphone when the set is in the receive position and no other station is being received. Another cause of poor reception may be signal absorbing objects, such as steel buildings, trees, hills, power and telephone lines, and large metal objects between the two units. The straight-line distance between units should be as clear of such objects as possible. Operation often will be improved by moving one or both sets to new locations. Placing the set as high as possible, as on top of a hill or building, will help to increase the range of operation. Be sure that the antenna is fully extended, held, as nearly as possible, in a vertical position, and clear of obstructions for several feet around it. When operating the unit in the underbrush, keep the antenna from coming in contact with branches or green foliage of any kind.

Precautions should be taken particularly in the early morning when dew is on the ground, or after a rainfall. Conditions of this kind may render the unit inoperative.

b. If the set does not work when the antenna is extended, that is, no sound is heard in the earphone, *check to see that the bottom section of the antenna is extended out of the case to its full length.* This is necessary to operate the power switch on the chassis.

c. If the set still does not work, refer to section IV for further corrective measures.

SECTION III

FUNCTIONING OF PARTS

	Paragraph
Receiver functioning.....	24
Basic receiver circuit.....	25
R-f amplifier.....	26
Converter-oscillator.....	27
I-f amplifier.....	28
Second detector—first a-f amplifier.....	29
Second a-f amplifier.....	30
Transmitter functioning.....	31
Basic transmitter circuit.....	32
Oscillator.....	33
R-f power amplifier.....	34
Microphone amplifier.....	35
Modulator.....	36
Change-over switch.....	37
Description of parts.....	38

NOTE.—This description is based on radio set SCR-536-C. SCR-536-A and B are similar except for minor differences.

24. Receiver functioning.—In the receive position, the set acts as a five-tube superheterodyne receiver consisting of one r-f amplifier stage, using a tube VT-174, one oscillator-mixer stage using a tube VT-171, one i-f amplifier stage using a tube VT-173, one diode detector and first audio amplifier stage using a tube VT-172, and one audio power output stage using a tube VT-174. The functional diagram of receiver is shown in figure 3.

25. Basic receiver circuit.—a. The antenna is series tuned by the mica trimmer C_7 . The signal voltage developed across C_7 is amplified by tube V_1 and applied to the grid of tube V_2 . In V_2 , the mixer-oscillator tube, the incoming signal is mixed with the oscillator signal generated in the tube and produces a beat frequency signal of 455 kc. The oscillator uses a crystal in a Pierce circuit, and functions at 455 kc above the carrier or incoming signal frequency. The receiver

crystal M_1 , therefore is 455 kc higher in frequency than the transmitter crystal M_2 .

b. The beat frequency or i-f signal produced in the mixer is amplified by tube V_2 and is applied to the diode section of tube V_4 . Due to the detection process, the modulated i-f signal is demodulated, and an audio voltage is impressed across R_{20} , the grid resistor of the pentode section of tube V_4 . The signal is then applied to the grid of tube V_5 , the power amplifier, where it is further amplified and then applied to the earphone.

26. R-f amplifier.—*a.* Capacitor C_1 is not necessary for the receiving function, but serves to block the d-c component of the plate voltage from the antenna rod in the transmit position. The inductance L_1 is a loading coil which aids in resonating the antenna. Resistor R_2 , the grid resistor of V_1 , provides a d-c path for the bias applied to the grid of tube V_1 and a high impedance to the r-f current, preventing it getting into the avc circuits. Capacitor C_7 is the antenna tuning capacitor. Capacitor C_3 is an r-f bypass for the filament circuit to reduce regeneration. Capacitor C_2 bypasses the r-f current from the screen. Resistor R_{18} helps make the bypassing of C_2 more effective as it increases the impedance of the path through the B battery BA-38. This arrangement is commonly called a decoupling filter. Resistor R_{18} also reduces the screen current.

b. The permeability-tuned inductance L_2 provides the r-f plate load for tube V_1 and is resonated by a capacitance made up of the distributed capacitance of the coil, the output capacitance of tube V_1 , the input capacitance of the tube V_2 , and the capacitance of circuit wiring. L_2 is adjusted to its operating frequency by a movable powdered iron slug.

c. Capacitor C_3 and resistor R_{10} make up a decoupling filter for the plate circuit of tube V_1 . The resistor R_{10} also serves to lower the plate voltage of tube V_1 which reduces its plate current and gives more economical operation of the B battery BA-38.

27. Converter-oscillator.—*a.* Capacitor C_{10} is the coupling capacitor which provides passage for the r-f current to the grid of tube V_2 , but prevents the d-c at the plate of tube V_1 from reaching the grid. Resistor R_1 is the grid resistor of tube V_2 . Resistors R_3 and R_4 make up the grid leak which provides the bias voltage for the oscillator grid as well as the bias voltage for the audio output tube VT-174. A voltage suitable for biasing purposes is produced across these resistors because of the d-c component of the grid current which exists as a result of driving the oscillator grid positive. The three resistors R_{29} , R_7 , and R_6 make up a voltage divider to provide the proper values of bias for tubes V_1 , V_2 , and V_3 when necessary to reduce regeneration.

b. Capacitors C_{13} and C_{14} , and resistors R_9 and R_{20} make up a filter for the automatic volume control (avc) voltage applied to the grids of tubes V_1 , V_2 , and V_3 . This avc voltage is obtained from the detector load resistance made up of resistors R_{13} and R_{14} . The filter removes the audio component of the detector voltage from the d-c component which is used for the avc function. Capacitors C_3 and C_{23} are r-f bypasses to prevent a voltage of the oscillator frequency getting into the grids of the other tubes through the bias system.

c. Capacitor C_4 is a neutralizing capacitor. It reduces the voltage of the oscillator frequency on the signal grid due to coupling within the tube, by feeding back a voltage of the oscillator frequency out of phase with the internally coupled voltage.

d. The r-f choke L_1 is a shunt feed arrangement for the screen grid of tube V_2 . It provides a low-resistance d-c path and a high-impedance r-f path to the screen grid.

e. The crystal M_1 connected between the No. 1 grid (oscillator grid) and the screen grid provides the coupling necessary for oscillation. This arrangement is known as the Pierce oscillator circuit.

f. Capacitor C_{11} and resistor R_{17} make up a decoupling filter for the screen circuit of tube V_2 .

28. I-f amplifier.—The first i-f transformer T_1 (two windings) is wound on iron cores and is surrounded by an iron sleeve to increase the inductance of the primary and secondary coils and to reduce their size. The coils are tuned by the trimmers C_{15} and C_{16} . Resistor R_{10} , which is contained within the shield, serves to broaden the response of the transformer. Capacitor C_{17} and resistor R_{12} make up a decoupling filter for the screen grid of tube V_2 . Capacitor C_{18} and resistor R_{18} comprise a decoupling filter for the plate circuit of tube V_2 .

29. Second detector—first a-f amplifier.—a. The second i-f transformer T_2 is also wound on an iron core and is surrounded by an iron sleeve. The trimmer C_{19} tunes the secondary.

b. Resistor R_{14} is the detector load across which the audio voltage is obtained. Resistor R_{15} and capacitors C_{20} and C_{21} make up a filter to remove the i-f component from the audio component of the detector voltage.

c. Capacitor C_{22} couples the detector to the grid of the 1st audio amplifier, and prevents the d-c component of the detector output from biasing this grid.

d. Resistor R_{20} is the grid resistor of the pentode section of tube V_1 . As it has 10 million ohms of resistance, the small amount of grid current which exists in the tube and flows through the resistor pro-

vides additional bias for this tube on large signal inputs. Capacitor C_{25} is an i-f bypass to eliminate any i-f current which exists in the plate circuit from getting into the audio plate load resistor R_{22} . Capacitor C_{26} and resistor R_{21} make up a decoupling filter for the screen. Register R_{22} is the plate load of tube V_4 , and C_{27} is the coupling capacitor.

30. Second a-f amplifier.—*a.* Resistor R_{23} is the grid resistor of tube V_5 . Capacitor C_{29} and resistors R_{24} and R_{15} make up a decoupling filter, for the screen of tube V_5 . Resistor R_{15} also helps reduce battery drain by lowering the screen current.

b. The audio choke L_4 provides a low resistance d-c path for the plate current, and offers a high impedance path to the audio plate current. Capacitor C_{30} and resistor R_{11} make up a plate decoupling filter. Resistor R_{11} also serves as a dropping resistor to lower the plate voltage. Capacitor C_{24} prevents the d-c at the plate from reaching the earphone.

c. Notice that only one filament section of each of the tubes VT-174 is used in the receive position. This arrangement reduces the A battery BA-37 drain.

31. Transmitter functioning.—In the transmit position only four tubes are used. The circuit consists of a crystal controlled oscillator in a Pierce circuit, which drives a tube VT-174 as an r-f power amplifier. The r-f power amplifier is plate modulated by a modulating amplifier made up of a voltage amplifier stage and a modulator stage. The functional diagram of the transmitter is shown in figure 4.

32. Basic transmitter circuit.—*a.* The r-f carrier is generated in the oscillator section of tube V_2 . The crystal used for the transmitter is 455 kc lower in frequency than that used for the receiver. The generated r-f voltage is applied to the grid of tube V_1 , where it is amplified and fed into the antenna. The antenna is coupled to the amplifier tank or tuned circuit by an impedance matching network of the π type in which the capacity between the antenna rod and housing makes up one shunt branch.

b. The microphone output is amplified by the pentode section of tube V_4 and then applied to the grid of tube V_5 , where it is further amplified. The output of tube V_5 is then fed into the plate circuit of tube V_1 , the r-f power amplifier. Notice that since the screen of tube VI is tied to the lower end of coil L_2 , the modulating voltage is introduced into the screen circuit as well as the plate circuit.

c. The earphone is also connected across the audio output so that the operator can hear what he is saying. This is known as sidetone.

33. Oscillator.—*a.* In the transmit position only the oscillator section of the tube VT-171 is utilized. Resistors R_3 and R_4 make up the grid leak which provides the bias voltage for the oscillator grid. The d-c component of the voltage developed across R_4 is used also for the grid bias for the modulator tube V_5 .

b. The r-f choke L_2 provides a shunt feed arrangement for the screen grid. Capacitor C_8 determines the amount of feedback to the grid. Capacitor C_{11} is the screen circuit bypass. Capacitors C_4 , C_{13} , C_{14} , and C_{22} are not necessary to the transmitter circuit; they are hold-overs from the receiver function. The same is true of resistors R_1 , R_{13} , R_9 , R_{14} , R_{25} , R_7 , and R_8 . These resistors, however, do tie the No. 3 grid of tube V_2 to ground.

34. R-f power amplifier.—*a.* Capacitor C_9 is the coupling capacitor and provides a path for the r-f current to the grid of tube V_1 , but prevents the d-c at the screen of tube V_2 from being applied to the grid. Resistor R_2 is the grid leak and provides the bias voltage for the grid of tube V_1 . Capacitor C_2 is the r-f bypass for the screen grid.

b. Coil L_2 is the r-f amplifier tank coil and C_{12} is the r-f amplifier tank turning capacitor. Capacitor C_{12} also acts as one branch of the π network connecting the antenna to the amplifier tank. The capacity between the antenna rod and the housing acts as the other shunt branch of the π network. In the receive position this antenna capacitance becomes a part of the tuning capacitance of the antenna. The antenna coil L_1 is the series branch of the π network, and also acts as the antenna loading inductance.

c. Capacitor C_3 is the plate circuit r-f bypass. The current jack in the plate of tube V_1 provides for the plate current measurement necessary for tuning up the power amplifier stage properly.

35. Microphone amplifier.—Resistor R_{20} is the grid resistor of tube V_4 , the first audio amplifier. Resistor R_{27} acts as a load resistor for the microphone. Resistor R_{21} and capacitor C_{23} act as a decoupling filter for the screen grid of tube V_4 . Resistor R_{21} also serves to obtain the proper operating voltage on the screen. Resistor R_{22} is the plate load. Capacitor C_{26} is a hold-over from the receiver function.

36. Modulator.—*a.* Capacitor C_{27} is the coupling capacitor, and R_{23} is the grid resistor of tube V_5 . Capacitor C_{29} and resistor R_{24} make up a decoupling filter for the screen grid of tube V_5 . Capacitor C_{28} provides a low impedance path around the modulation choke L_1 for the current of the carrier frequency. This is necessary as the r-f amplifier tank and modulator choke are in series. The modulator choke L_1 provides a low resistance d-c path to the plate of the modu-

lator and r-f amplifier tubes, and offers a high impedance load to the audio frequency plate current of the modulator.

b. Resistor R_{10} prevents overloading the monitoring earphone, as the audio output for modulating the r-f amplifier is quite high. Capacitor C_{20} removes the d-c at the plate of tube V_5 from the earphones. Capacitor C_{20} as well as capacitor C_{11} are B battery BA-38 bypasses.

37. Change-over switch.—The press-to-talk switch operates the change-over switch which makes the necessary circuit changes to convert the set from a receiver to a transmitter. The change-over switch is made up of 14 sections. Each section has a name which is marked on the celluloid insulating strip covering the change-over switch. For simplicity, however, each section has been designated by a letter of the alphabet on the schematic and functional drawings. (See figs. 3, 4, 16, and 17.)

a. Section *A* connects the proper crystal into the circuit.

b. Section *B* connects the voltage divider made up of R_{26} , R_7 , and R_3 across resistor R_4 in the receive position, and disconnects the voltage divider in the transmit position. This voltage divider provides the grid bias voltage, for tubes V_1 , V_2 , and V_3 .

c. Section *C* connects the control grid of tube V_1 to the avc voltage line in the receive position, and connects the control grid to the grid leak resistor R_6 in the transmit position.

d. Section *D* connects the antenna to the tuning capacitor C_7 in the receive position, and to the plate of the r-f amplifier tube VT-174, in the transmit position.

e. Section *E* connects the plate of the r-f amplifier tube V_1 to the coupling capacitor C_{10} of the signal grid of the mixer tube V_2 in the receive position, and connects the plate to the r-f amplifier tank capacitor C_{12} in the transmit position.

f. Section *F* connects the oscillator feedback control capacitor C_6 to ground in the receive position, and connects capacitor C_6 to the oscillator grid of tube V_2 in the transmit position.

g. Section *G* puts the voltage dropping resistor R_{10} in series with the plate of tube V_1 in the receive position, and shorts out the resistor in the transmit position.

h. Section *H* connects the B battery BA-38 to the plate and screen of V_2 in the receive position, and disconnects the battery in the transmit position. Section *H* also puts the voltage dropping resistor R_{11} in series with the plate of tube V_5 in the receive position, and shorts out the resistor in the transmit position.

i. Section *J* grounds the microphone in the receive position, thereby eliminating the possibility of pick-up on the microphone being intro-

duced into the audio amplifier. In the transmit position section *J* connects the microphone to the grid of the first audio amplifier tube V_4 .

j. Section *K* in the receive position connects the filament of tube V_3 to the A battery BA-37 and disconnects one filament section of each tube VT-174 from the A battery BA-37. Eliminating one filament section of each tube VT-174 reduces the total A battery BA-37 drain by 100 milliamperes in the receive position.

k. In the transmit position, the filament of tube V_3 is disconnected from the A battery BA-37 and the second section of the filament in each tube VT-174 is connected to the A battery BA-37. Since one filament is cut out and two are cut in, the drain is only 50 milliamperes higher in the transmit position as compared with the drain in the receive position.

l. Sections *L* and *M* are tied together electrically through the moving element of the switch. In the receive position the dropping resistor R_{16} is placed in series with the screen grid of tube V_3 by sections *L* and *M*. These switch sections also place the dropping resistor R_{17} in series with the screen circuits of tubes V_1 and V_2 , and connect the B battery BA-38 to the plate of tube V_{1c} . In the transmit position resistors R_{17} and R_{16} are shorted out by switch sections *L* and *M*.

m. Sections *N* and *O* are tied together electrically through the moving element of the switch. In the receive position they place the earphone across the audio choke in the plate of tube V_3 , and in the transmit position they connect the screen and plate circuits of the r-f amplifier, tube V_1 , to the plate of the modulator tube V_5 . This switch section also places the dropping resistor R_{19} in series with the earphone to reduce the intensity of the signal in the earphone in the transmit position.

38. Description of parts.—*a. Resistor-capacitor containers.*—On the chassis there are four resistor-capacitor containers which are called cups. These cups fit around the tube sockets and are attached to them with cement. The purpose of the cups is to provide tie terminals and a place for some of the resistors and capacitors used in the set. Each cup consists of a thin bakelite shell of circular shape, with an inner and outer wall. The resistors and capacitors are placed in the space between these walls. Impregnating compound seals these parts into the cup. The top piece joining the two walls is drilled so that the leads from the capacitors and resistors can be brought out. Some of the parts are soldered to terminals riveted to the top piece of the cup.

Each cup has a part number marked on it, as well as a schematic drawing of the parts in it. (See fig. 23.)

b. Antenna coil.—The antenna coil is of the solenoid type and is wound on a polystyrene form. This is a plug-in coil and has three pins on its base. Two of these pins are connected to the coil. The top of each coil is marked with the name, the frequency, and the part number. The antenna coil socket is also of polystyrene, and is fastened to the chassis by a long rivet through its center. This rivet also fastens the antenna clamp and the antenna polystyrene support to the chassis.

c. Plate circuit tank coil.—The tuned r-f amplifier plate coil has been marked TANK and is wound on a small mica filled bakelite form. The coil is permeability tuned and has a powdered iron core in the form of a hexagon nut. The winding and core are not visible as they are surrounded by a bakelite shell which completely incloses them. This shell is riveted to the coil form. A threaded bakelite screw fits into the threaded iron core, and motion of the screw moves the core relative to the winding thereby determining the inductance value.

(1) In addition to the word TANK the coil is marked with the frequency and the part number. The Signal Corps part number carries the letter C as a prefix to the part number. This identifies it and eliminates confusing it with the frequency numbers. Coils issued with radio set SCR-536-A are marked with the frequency range and the part number.

(2) The coil form has a female type base. The coil socket contains two pin connections which fit into holes in the coil form and make electrical contact to the coil. The pins are gripped by spring clip connections in the base of the coil form. A hole is provided in the socket for the inductance adjusting screw which extends through the form. A spring clip in the socket grips the tuning screw and provides a more rigid support for the coil. A spring clip on top of the form prevents the coil from working loose from the socket.

d. First i-f transformer.—The i-f transformer windings are on a powdered iron core and are surrounded by a powdered iron sleeve to further increase their inductance. This type of construction gives a high inductance with a small winding which results in a small size transformer. The primary and secondary of the first i-f transformer

are tuned by small adjustable mica trimmers contained in the shield can. The adjustment of the trimmers is reached through two holes in the top of the can. A one megohm resistor is shunted across the secondary winding and serves to broaden the response of the transformer. This resistor is contained in the shield can. The transformer is held in the can by a metal bottom plate which is secured by rolling the side walls of the shield over the edges of the plate. Two U-shaped clamps riveted to the back side of the chassis hold the transformer in place.

e. Second i-f transformer.—(1) The second i-f transformer construction is similar to that of the first i-f transformer. Only one trimmer is used, however, and it is connected across the secondary winding. This trimmer is accessible through a hole in the top of the shield can.

(2) A 220,000-ohm resistor and two 70- μ f-mica capacitors are also mounted in the shield can. The transformer fastens to the chassis in the same manner as the first i-f transformer. They make up an i-f filter for the detector circuit.

f. Crystals.—(1) There are two crystals used in the radio receiver and transmitter BC-611-(*). The receiver crystal is 455 kc higher in frequency than the transmitter crystal. The crystals are contained in plug-in type holders with two pin connections. They are completely sealed against moisture. The receiver crystal holder is plainly marked REC. and the transmitter crystal is marked TRAN. Each crystal holder has an arrow indicating the direction in which it should be placed in the socket. As the sockets carry a similar marking, the possibility of getting the crystals into the wrong socket or seated improperly is minimized.

(2) The crystal holder has a metal cover plate on which are marked the frequency, crystal manufacturer's name, and the model number. This plate does not make contact with the crystal blank in the holder, but it does have a capacitive effect on the crystal. If it comes in contact with the chassis or metal clamp which holds the crystal in the socket, the operation of the crystal will be affected. A piece of insulation material covers the chassis where the transmitter crystal might touch when the set is jarred. When the crystal activity is low, it should be replaced with another. Do not attempt to take the holder apart.

SECTION IV

MAINTENANCE

	Paragraph
General.....	39
Replacement of batteries.....	40
Replacement of tubes.....	41
Replacement of antenna coil.....	42
Replacement of r-f tank coil.....	43
Replacement of microphone.....	44
Replacement of earphone.....	45
Removal and replacement of crystals.....	46
Weak signals.....	47
No signals.....	48
Test equipments.....	49
Test equipment IE-17-(*).....	50
Test case CS-81-(*).....	51
Test stand FT-252-(*) and Antenna A-82-(*).....	52
Test unit I-135-(*).....	53
Presetting frequency with IE-17-(*).....	54
Removal and replacement of coils and crystals.....	55
Setting up test equipment IE-17-(*).....	56
Crystal activity test.....	57
Presetting receiver.....	58
Presetting transmitter.....	59
Procedure if badly out of alinement.....	60
Using signal generator.....	61
I-f alinement using test equipment IE-17-(*).....	62
Testing batteries BA-37 and BA-38.....	63
Test equipment IE-15-A.....	64
Use of test case CS-81-(*).....	65
Use of test stand FT-252-(*).....	66
Test harness and meters.....	67
Use of test set I-56-(*).....	68
Presetting frequency with IE-15-A.....	69
Changing coils and crystals.....	70
Setting up test equipment IE-15-A.....	71
Presetting receiver with IE-15-A.....	72
Presetting transmitter with IE-15-A.....	73
I-f alinement.....	74
Checking for image frequency.....	75
BC-611-(*) as signal generator.....	76
Replacement of parts.....	77
Trouble location and remedy.....	78

39. General.—Maintenance work on this equipment should be done by qualified radio repairmen only. A logical process of checking accessories such as tubes and batteries, when the radio set operates poorly, will often locate the trouble.

40. Replacement of batteries.—See paragraph 11a.

41. Replacement of tubes.—Remove the chassis from the housing. To do this, unfasten the bottom cover of the housing and remove the batteries. Disconnect the microphone and earphone plugs from the terminal board on the end of the chassis by gently pulling out. Plugs and jacks are color coded with small spots of color: green for microphone and red for earphone. Remove the mounting screw in the top cover of the housing, and the chassis can be slid out of the bottom of the housing. Lift the tube retainer bracket at the top of the tube and remove the shield, if there is one. Insert a narrow rod through the bottom center of the tube socket and gently force the tube out. A small narrow-bladed screw driver will be found useful for this purpose. When replacing the tube, be sure it is the right type, that the base of the tube is so turned that the pins fit into the socket properly and are straight. The wide space between pins 1 and 7 of the tube can be used as a guide to line the tube with the socket. (See fig. 10.)

42. Replacement of antenna coil.—See paragraphs 55 and 70.

43. Replacement of r-f tank coil.—See paragraphs 55 and 70.

44. Replacement of microphone.—Remove the batteries, cardboard separator, and chassis from the housing. Then unscrew the bakelite microphone cover on the housing and the unit can be lifted out of the housing. To detach the microphone unit from the housing, it will be necessary to remove the screw which grounds one of the two leads to the housing. The lead with the connecting plug (green dot), which fits into the jack on the terminal board, is withdrawn through the hole in the housing.

45. Replacement of earphone.—The earphone is replaced in the same manner as the microphone.

46. Removal and replacement of crystals.—See paragraphs 55 and 70.

47. Weak signals.—If the distance between units in operation is between 100 feet and 1 mile, and the transmission is poor, the batteries may be weak. The batteries are designed to give about 15 hours of operation, assuming that the unit is operated for long periods of time and that the operator is transmitting much of the time. They will last longer if not used constantly. A sign of weak batteries is a low noise level in the earphone when the set is in the receive position with no incoming signal.

48. No signals.—a. If the batteries are placed in the battery compartment, positive end first, the set will not operate. If the batteries are inserted correctly and the set does not operate, the batteries may be dead. Replace them with a new set of batteries.

b. A tube may be burned out or shorted. Remove the chassis from the housing. (See par. 41.) Locate the defective tube and replace it. Reinstall the chassis in the housing. Take care that the chassis fits between the guides provided for it in the case.

c. Make certain that the plate current jumper (fig. 1) is inserted in its proper place. The set will not operate if this jumper is missing.

49. **Test equipments.**—The test equipments are designed to simplify testing, frequency presetting and general alinement of radio receiver and transmitter chassis BC-611-(*) which is the heart of radio set SCR-536-(*). IE-17-(*) is an improved version of IE-15-A. The components and method of using both of these equipments is described in the following paragraphs. Either equipment may be used with all models of radio set SCR-536-(*).

50. **Test equipment IE-17-(*).**—This equipment consists of the following components:

Antenna A-82-(*), artificial.

Test stand FT-252-(*).

Test case CS-81-(*).

Test unit I-135-(*), containing multi-range meter, harness, r-f and a-f oscillators, insulated screw driver, and battery connectors. (This unit combines in one case all the meters and additional equipment required with test equipment IE-15-A.)

51. **Test case CS-81-(*).**—As the tuning adjustments are inaccessible because of their location on the chassis, which is covered by the case or housing, a special housing is required to make these adjustments. (See fig. 5.) Test Case CS-81-(*) is similar to the radio set housing except for the holes that have been provided to permit access to the chassis adjustments. This apparatus permits tuning the set under conditions identical to those of normal operation. The presetting adjustments should not be made on the set without the test case being around the chassis, because the set would become detuned when inserted into the regular housing. This detuning or misalinement would result from the additional capacitance introduced into the circuit by the housing.

52. **Test stand FT-252-(*), and antenna A-82-(*).**—a. The test stand contains clamps to hold the test case and the dummy antenna.

b. Antenna A-82-(*) comprises a 50-milliamperere r-f milliammeter to measure antenna current and a receiver and transmitter dummy antenna consisting of a receive-transmit switch, a 56-ohm resistor, and a variable capacitor of 8 μ f maximum capacitance.

53. Test unit I-135-(*).—This unit is a multirange voltmeter and milliammeter, a crystal tester, and an r-f and a-f signal source (fig. 6). Test unit I-135-(*), is used for the measurement of battery voltage and current, r-f amplifier plate current, audio output voltage, and crystal activity. It is used as a modulated r-f signal source for the alinement of the receiver and as an a-f signal source for determining the modulation capability of the transmitter. It combines in one case all the meters and additional apparatus required for test equipment IE-15-A.

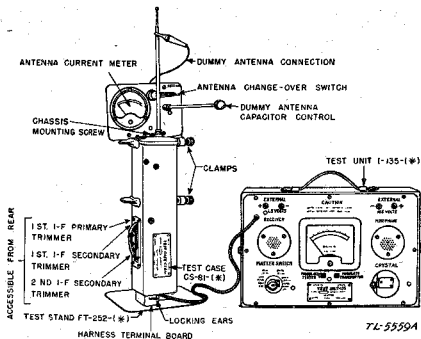

FIGURE 5.—Test equipment IE-17-(*)—set up.

a. The r-f signal source is a Pierce crystal oscillator and makes use of the radio set transmitter crystal such as is contained in radio receiver and transmitter BC-611-(*), or one of the same frequency. It generates a signal of the carrier frequency. This r-f oscillator also serves to check both the receiver crystal and the transmitter crystal for activity.

b. The a-f signal source is a Colpitts oscillator generating a signal of 1,000 cycles per second. This tone is used to modulate the r-f oscillator and can be applied also to the microphone input terminals of the transmitter to test for modulation capability.

c. A test harness attached to the test unit provides the means for connecting to the chassis. (See *d* below.) An insulated screw driver attached to the cover of the test unit is for aligning purposes.

d. Compartments are provided in the test unit for A battery BA-37 and B battery BA-38 to permit these batteries to be tested under load. (See fig. 7.) Also connections are provided for the use of external batteries. A heavy-duty 1.5-volt battery (battery BA-23 or battery BA-35) and a heavy-duty 90-volt battery (two batteries BA-26 or two batteries BA-36) will be satisfactory for all alinement and testing purposes. Battery BA-37 and battery BA-38, part of radio receiver and transmitter BC-611-(*), also can be used for this purpose, but are not recommended because of their short life under these conditions.

e. The positions of the MASTER SWITCH of the test unit are as follows:

(1) OFF, which disconnects external and internal batteries of test unit I-135-(*) from both the test unit and the radio set chassis. The radio set and oscillator are ON in all other positions of the MASTER SWITCH.

(2) BA-37, 0-3V. D.C., which indicates on the meter the voltage of external A battery or battery BA-37 when the radio set is in either the receiver or transmit position.

(3) BA-37, 0-600 MA. D.C., which indicates on the meter the current drain of external A battery or battery BA-37 when the radio set is in either the receive or transmit position.

(4) BA-38, 0-150 V. D.C., which indicates on the meter the voltage of external B battery or battery BA-38 when the radio set is in either the receive or transmit position.

(5) BA-38, 0-60 MA. D.C., which indicates on the meter the current drain of external B battery or battery BA-38 when the radio set is in either the receive or transmit position.

(6) PWR. AMP., 0-15 MA. D.C., which indicates on the meter the r-f power amplifier plate current when the radio set is in transmit position.

(7) OUTPUT 0-60 V. A.C., which indicates on the meter the audio output voltage of the radio receiver; the meter is connected across the earphone in the test unit.

(8) CRYSTAL ACTIVITY, 0-1.5 MA. D.C., which indicates on the meter the grid current of the crystal oscillator to show condition of crystal. The MODULATE TESTER switch must be OFF when crystal activity is being checked.

(9) The switch marked MODULATE TESTER is used to modulate the r-f oscillator with a 1,000-cycles-per-second tone when the test unit is to be used for receiver alinement purposes.

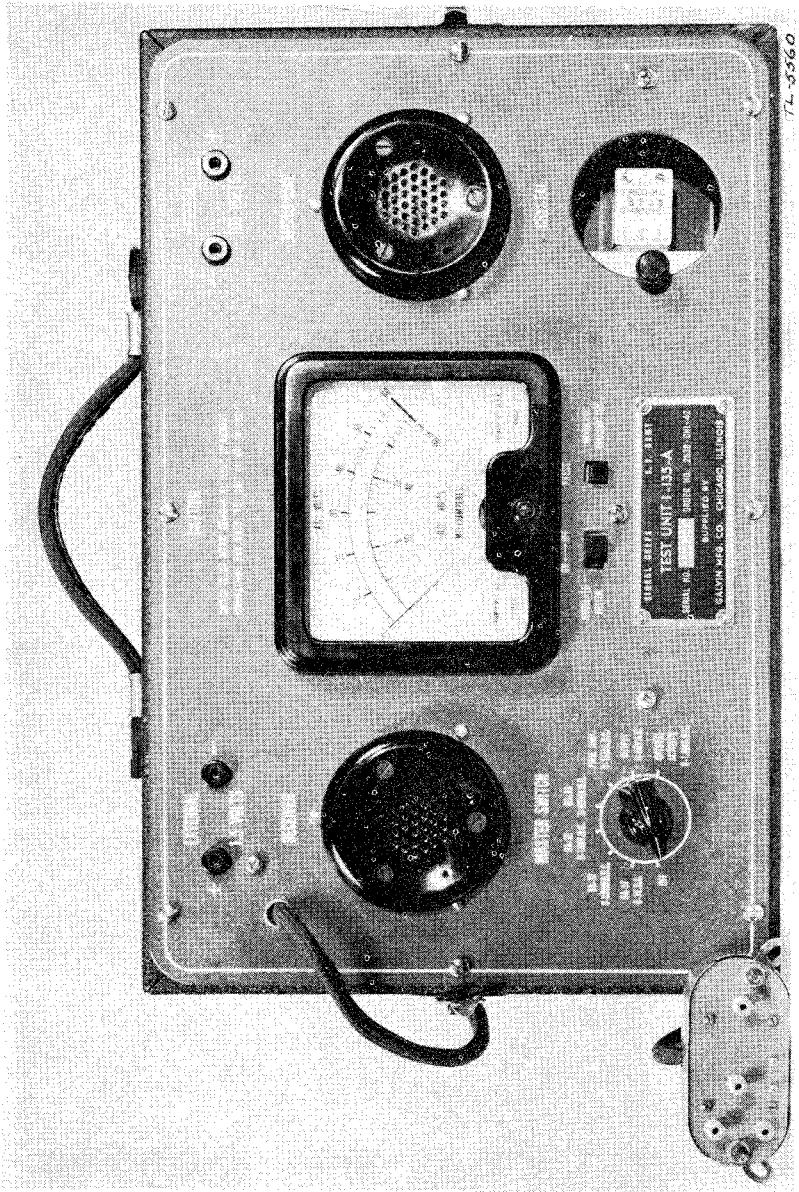

FIGURE 6.—Test unit I-135-(*).

f. The switch marked **MODULATE TRANSMITTER** applies a 1,000-cycles-per-second audio voltage across the microphone input circuit of the transmitter as a test of the modulation capability of the transmitter.

NOTE.—The **MODULATE TESTER** switch must be **ON** and a crystal must be in place in the compartment socket when this test is made.

g. Test unit **I-135-(*)** also contains an earphone and a microphone which are mounted in the front panel of the case. These can be used to listen to the audio output of the receiver or to modulate the transmitter by speaking into the microphone.

54. Presetting frequency with IE-17-(*).—To cover the authorized range of frequencies from 3.5 to 6.0 megacycles, individual matched sets of antenna coils, r-f tank coils, and crystals are available. Each coil is marked with its frequency and part number so that errors of coil selection will be minimized.

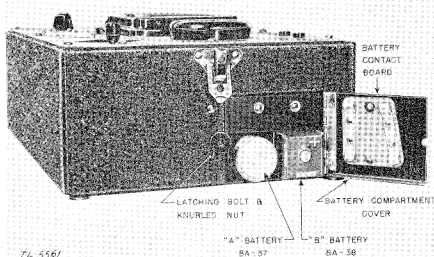

FIGURE 7.—Test unit **I-135-(*)**—showing battery compartment.

NOTE.—The coils supplied with radio set **SCR-536-A** are not preset to one frequency. Instead each is adjustable over the small frequency range marked on the coil. The frequency range of each is indicated in chart I (par. 70). The coils manufactured for radio sets **SCR-536-B** and **536-C** are identical but have been preset to the frequency indicated on each.

a. To preset the operating frequency of the radio receiver and transmitter **BC-611-(*)**, obtain a coil and crystal equipment of the desired frequency. The coil and crystal equipment comes in an indi-

vidual carton marked with the frequency and contains the transmitter and receiver crystals, the antenna coil and the r-f tank coil.

NOTE.—Radio sets SCR-536-A are issued with one set of spare crystals. The coils for these radio sets are available in the frequency ranges indicated in chart I (par. 70). Radio set SCR-536-B is issued with only one set of coils and crystals. Radio set SCR-536-C is issued with box BX-49 containing 12 sets of antenna coils, 12 sets of r-f tank coils and 12 sets of crystals (to cover operation on 12 different frequencies).

b. The antenna coil is larger and of different shape than the r-f tank coil. Its base connections also differ, so it is impossible to put the coils in the wrong sockets. Both coils are of the plug-in type. (See figs. 8 and 10.)

c. Remove the chassis of radio receiver and transmitter BC-611-(*) from its housing. To do this, unlatch the bottom cover of the housing and remove the batteries. Place them aside for test. Disconnect the microphone and earphone plugs from the terminal board on the end of the chassis by gently lifting them up. Next remove the screw in the top cover of the housing; the chassis then will slide out of the bottom end of the housing.

55. Removal and replacement of coils and crystals.—*a. Antenna coil.*—Remove the plug-in antenna coil by carefully lifting it out of its socket. See figure 10 for its location. In its place insert another coil of the desired frequency.

b. R-f tank coil.—To remove, loosen the screw holding down the coil retainer spring on top of the coil. (See fig. 9.) Swing the spring free of the coil. The coil then can be lifted out of the socket. When replacing with another coil of the desired frequency, carefully fit the coil over the two pins projecting up from the socket so that the pins fit into the holes in the coil form and the coil adjustment shaft fits into the hole in the socket. Gently press the coil into the socket, replace the coil retainer spring on top of the coil, and tighten the screw holding the spring.

c. Crystals.—The crystals are mounted in plug-in type holders. (See fig. 10.) To remove a crystal, lift up the clamp located on top of the crystal holder. This clamp pivots on a stud fastened to the chassis. Place a small screw driver between the crystal holder and the socket and gently pry it up. To remove the other crystal holder, the same procedure is followed. Select a transmitter and a receiver crystal holder of the desired frequency (the frequency of the transmitter crystal will be the same as that of the coils, while the receiver crystal will be 455 kc higher in frequency). Insert the receiver crystal holder in the crystal socket marked REC. It should be inserted so that the frequency printed on the metal side faces out and the

arrow on the holder points in the same direction as the arrow on the socket. When the transmitter crystal is inserted, place it in the socket marked TRAN. in exactly the same way. The printed metal

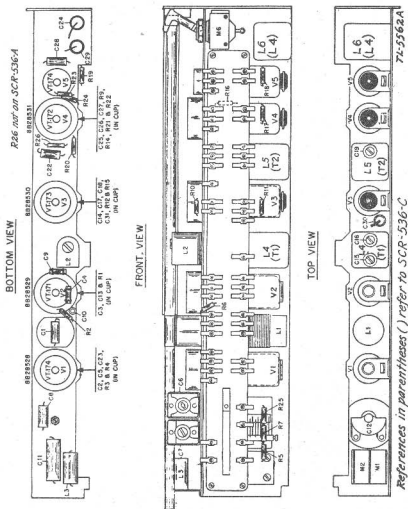

side of the holder should show through the opening in the chassis. However, do not insert the transmitter crystal in the radio set at this time. Instead, replace the metal clamp on the receiver crystal holder on the chassis and leave the transmitter crystal socket empty.

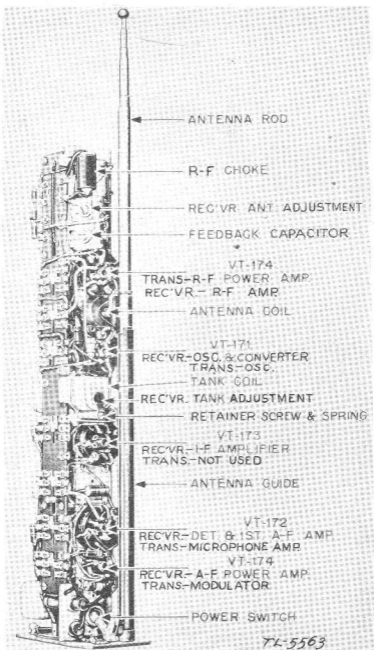

FIGURE 9.—Radio receiver and transmitter BC-611-(*)—bottom view of chassis.

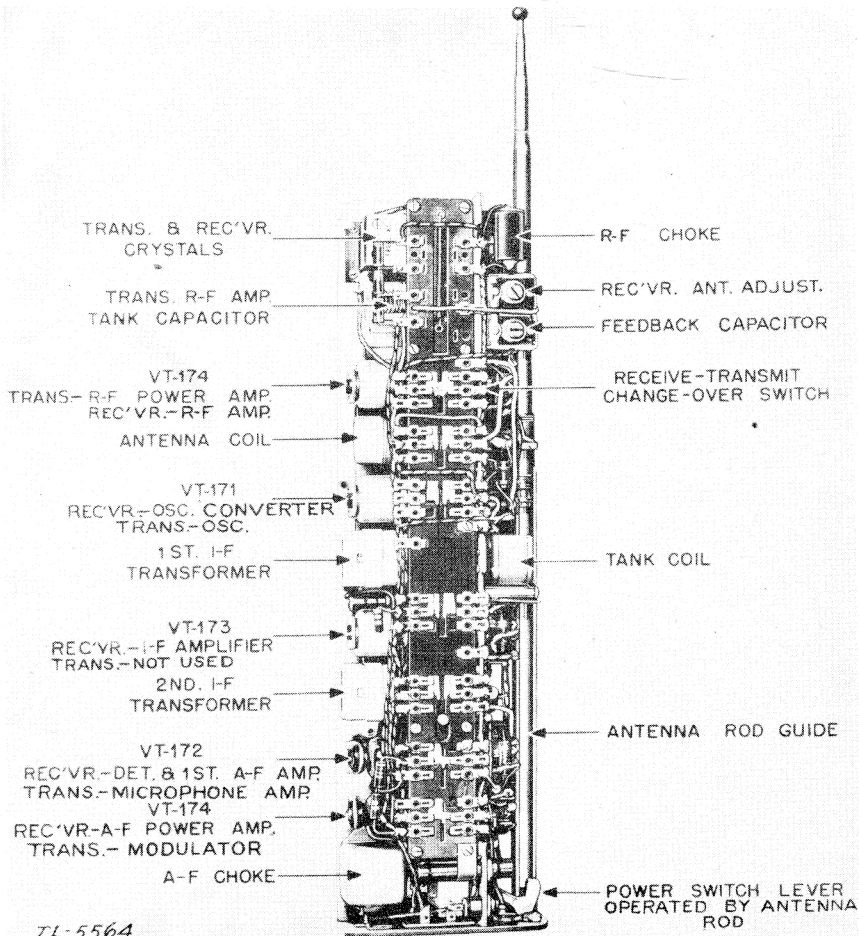

FIGURE 10.—Radio receiver and transmitter BC-611-(*)—front view of chassis.

56. Setting up test equipment IE-17-(*).—*a.* Place the chassis into test case CS-81-(*) housing. The chassis must be inserted into the test case through the bottom as is done when inserting the chassis into its own housing. Take care that the chassis fits between the guides provided for it in the case. It should not be necessary to force the chassis. If force is necessary, withdraw the chassis and check to see that no parts are catching on the test case or that the chassis has not jumped the guides. Slip the top cover over the antenna rod and fasten the chassis to it with the knurled mounting screw. The chassis now will be held securely in the test case. *Now*

remove the plate current meter jumper from the terminal board at the bottom end of the chassis.

Caution: Do not misplace this jumper since it must be replaced after alignment tests.

b. Attach the terminal board of the I-135-(*) harness to the terminal board of the chassis so that the two small pins on the harness terminal board fit into the plate current meter jacks, and that the two large locking pins, one on each end of the terminal board, fit into the holes provided for them. Lock the two terminal boards together by a sideward movement of the levers attached to the locking pins.

c. Next, clamp test case CS-81-(*) into test stand FT-252-(*) with the antenna end up, and the housing in such position that the change-over switch is opposite the left side of the operator as he faces the stand. (See fig. 5.) The upper clamp should grip the housing on the edges of the top cover. The lower clamp should not be made too tight, as the pressure may crack the housing.

d. Make certain that the MASTER SWITCH of test unit I-135-(*) is in the OFF position. Place the transmitter crystal holder of the desired frequency in the crystal socket in the front panel compartment of test unit I-135-(*). (See fig. 6.) Be sure the crystal is of the same frequency as the coils in the radio set and that its frequency is 455 kc less than the receiver crystal. Connect external 1.5-volt and 90-volt heavy duty batteries (of the type described in paragraph 53d) to the battery terminals marked EXTERNAL 1.5 VOLTS and EXTERNAL 105 VOLTS on the front of I-135-(*).

57. Crystal activity test.—Be sure that the transmitter crystal has been properly placed in the crystal socket of the test unit. Place the MODULATE TESTER switch in the OFF position. Then turn the MASTER SWITCH to the CRYSTAL ACTIVITY position. The meter should read between .3 and .8 milliamperes. If it reads less than .3 milliamperes the crystal is defective and must be replaced. Before replacing a crystal for poor activity, be sure that the external battery voltages applied to the test unit I-135-(*) are 1.5 and 90 volts. *The foregoing tests apply equally well to receiver crystals.* Turn in defective crystals for salvage. Leave a good transmitter crystal of the proper frequency in place in test unit I-135-(*) for receiver frequency presetting adjustments.

58. Presetting receiver.—Use the following procedure:

a. Extend the radio set antenna rod to its full length, 39 inches above the top cover of test case CS-81-(*). This will turn on the radio set. *Do not press the press-to-talk switch of the test case during the receiver presetting adjustments.*

b. Before proceeding with the necessary set adjustments, check operating voltages and currents, using the multirange meter of test unit I-135-(*). The following voltage and current readings are normal:

Master switch set at.	{ BA-37 0-3 V. D. C.	{ BA-37 0-600 MA. D. C.	BA-38 0-150 V. D. C.	BA-38 0-60 MA. D. C.
Meter should read...	1.35 (min) ¹ to 1.5 v.	250 ma....	85 v (min) ¹ .	5-11 ma.

¹ Replace batteries if voltage is less than minimum figure.

c. The receiver is now ready for alinement. Be sure that a good transmitter crystal of the proper frequency is in place in the test unit. The preceding activity check of the transmitter crystal will assure that a radio-frequency signal is being generated.

d. Turn the MASTER SWITCH to OUTPUT, 60 V. A. C., position. A reading should now be indicated on the meter and a 1,000-cycles-per-second tone should be heard in the earphone of the test unit.

e. Set the MODULATE TESTER switch to ON. The 1,000-cycles-per-second tone will now modulate the carrier signal.

NOTE.—The r-f signal for alinement is fed into the receiver by radiation from the compartment of the test unit in which the crystal is located. The slide cover of the crystal compartment acts as a radiation control preventing the signal from radiating when closed and allowing maximum radiation when open. If the set is badly out of alinement, the r-f signal picked up by the receiver may not be sufficient to give a reliable audio voltage reading on the meter (OUTPUT 0-60 V. A. C. position). For such a condition, connect a short piece of wire to the Fahnestock clip marked R-F. OUTPUT. This clip is located in the crystal compartment of the test unit. The wire will act as an antenna and increase the radiation of the r-f signal. Varying the position of this wire with respect to the antenna of the radio set or varying the length of the wire will control the strength of the signal radiated. In extreme cases of misalignment the wire connected to the R-F OUTPUT terminal may have to be wrapped a couple of turns around the radio set antenna.

f. Grasp the test case with one hand during the following alinement adjustments on the receiver.

g. The location of the receiver tuning adjustments on the radio chassis are shown in figures 5 and 11. With the insulated screw driver, turn the receiver antenna adjustment screw clockwise. Notice the effect of this adjustment on the output meter reading. If the meter reading *increases*, continue to tighten the screw until a maximum reading is obtained. If the reading *decreases*, turn the screw counterclockwise until a maximum reading is obtained. Be careful

not to tighten the screw after it begins to turn hard as the threaded base of the trimmer will be stripped. The setting of the trimmer screw for maximum output should fall somewhere between the point of hard tuning and that of minimum pressure. If the maximum is not reached in these limits of the screw adjustment, try another antenna coil. *If the set appears to be badly out of alinement, proceed as indicated in paragraph 60.*

Antenna fully extended

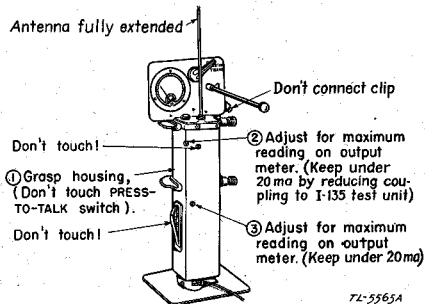

FIGURE 11.—Receiver presetting adjustments.

NOTE.—Be sure that the r-f signal is not strong enough to cause overloading the receiver. If this condition exists, adjustment of the receiver antenna trimmer will have little or no effect on the output reading. Best results will be obtained if the r-f input is adjusted so that the meter reading on the 60-volt scale does not exceed 10 volts, although satisfactory results may be obtained with readings up to 20 volts.

h. Using the *insulated screw driver*, turn the *receiver tank adjustment screw* for maximum output using the same method employed in step *g* above.

NOTE.—This screw, which is made of bakelite, fits into a powdered iron core which is threaded. The movement of the screw changes the position of the core in the coil. If the screw is turned too far clockwise, the core will ride up against the screw head, and the threads in the core will be stripped. If the screw is turned too far counterclockwise, the core will come in contact with the coil socket, and further turning will again strip the core threads. The screw setting for maximum output should fall somewhere between these two limits of adjustment. If it does not, a wrong tank coil may be in the set.

i. Turn the **MASTER SWITCH** to **OFF**. Remove the transmitter crystal from test unit I-135-(*). Telescope the rod antenna and remove the test harness and the knurled fastening screw from the chassis in the test case. Then slide the chassis out of the test case and remove the receiver crystal and install it in I-135-(* test unit. Insert the transmitter crystal in its proper socket in the radio set, making sure it is properly installed, and put the chassis back in the test case. (See par. 55.) Attach top cover and the harness terminal board. Put test case in place on the test stand. Then test the receiver crystal for activity in the same manner as for the transmitter crystal (par. 57). *Leave a good receiver crystal in place in the test unit while presetting the transmitter portion of the radio set.*

59. **Presetting transmitter.**—a. Grasp the test case and depress the press-to-talk switch with one hand during all following presetting adjustments of the transmitter. The **MODULATE TESTER** switch should be **OFF** unless otherwise specified.

b. Extend the antenna of the radio set to its full length. This will operate the power switch in the radio set chassis.

c. Before proceeding with the necessary set adjustments, check operating voltages and currents, using the multirange meter of test unit I-135-(*). The following voltage and current readings should be obtained with press-to-talk switch on the radio set depressed:

Master switch set at.....	{ BA-37 0-3 V. D. C.	{ BA-37 0-600 MA. D. C.	BA-38 0-150 V. D. C.	BA-38 0-60 MA. D. C.
Meter should read.	1.35 (min.) ¹ to 1.5 v.	275-300 ma.	75 v. (min.) ¹	26-30 ma.

¹ Replace batteries if voltage is less than the minimum figure.

d. The transmitter is now ready for alinement. Turn the **MASTER SWITCH** on test unit to **PWR. AMP.** position. Adjust the *transmitter tank adjustment* screw for *minimum* current reading on the meter in the test unit. The normal reading in this position is approximately 7 milliamperes. See figures 5 and 12 for location of *transmitter tank adjustment*. *Be sure to depress the press-to-talk switch with one hand during this operation.*

e. Telescope the upper three sections of the antenna rod, leaving only the bottom or fourth section fully extended from the housing. Clip the *dummy antenna connection* to the upper part of the antenna rod. (See fig. 12.) Set the *antenna change-over switch* on the panel of test stand FT-252-(* to **TRANS.** position, and then, still

grasping the test case and press-to-talk switch, use the insulated shaft extension to adjust the *dummy antenna capacitor control* for *minimum current reading on the meter in test unit I-135-(*)* (approximately $7\frac{1}{2}$ ma in PWR. AMP. position). This adjustment of the dummy antenna capacitance for minimum power amplifier plate current is necessary to compensate for the change in antenna capacitance due to telescoping the upper three sections of the antenna rod. Observe the reading of the *antenna current meter* on test stand FT-252-(*). This should be from 15 to 24 milliamperes and represents the unmodulated antenna current.

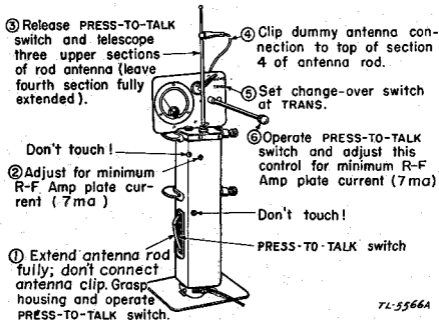

FIGURE 12.—Transmitter presetting adjustments.

f. (1) Place the **MODULATE TESTER** switch to ON position and press the **MODULATE TRANSMITTER** button on the test unit. This modulates the transmitter by applying a .2-volt, 1,000-cycles-per-second audio signal across the microphone terminals. Note the rise in the *antenna current meter* reading when the modulated signal is applied. This rise should be at least 6 percent over the unmodulated current reading. A 6 percent increase in antenna current indicates 50 percent modulation. For example, assume that the unmodulated

antenna current is 20 milliamperes and that the modulated current is 22 milliamperes:

The increase in current is then

$$22/20 = 2 \text{ milliamperes;}$$

The percentage increase will be

$$2/20 \times 100 = 10 \text{ percent.}$$

(2) Another method is to divide the antenna current obtained with modulation by the antenna current without modulation; the answer should be greater than 1.06. For example, take the values of current previously given. Dividing the modulated current by the unmodulated current gives $22/20 = 1.10$.

NOTE.—Further checks on modulation may be made by whistling into the microphone or holding a sustained note. The modulation rise should be substantially greater. MODULATE TRANSMITTER button must not be pressed when using the microphone method.

g. This completes normal frequency presetting adjustments. Remove the chassis from the test case, replace in the radio set housing and reconnect microphone and earphone. *Be sure to replace the plate current meter jumper.* Reinstall the A and B batteries, making certain that the positive (+) ends face outward. Close the cover, move the latching bolt into place, and tighten the knurled nut. The set is now ready for operation.

60. Procedure if badly out of alinement.—If the i-f transformers are badly out of alinement, it may be impossible to get a carrier-frequency signal through the receiver as outlined in paragraph 58. For such a condition, the i-f transformers must be realined. There are two ways of doing this, one way being to use a 455-kc signal generator connected to the signal grid of the mixer tube, while the second method makes use of test equipment IE-17-(*).

61. Using signal generator.—a. Remove the chassis from the test case and with the mounting screw fasten it to the top cover of the housing. Place the chassis in the test stand in the same relative position as when in the test housing, and hold it there by gripping the housing cover with the upper clamp of the test stand. (See fig. 13.) Leave test unit I-135-(*). connected to the chassis by means of the harness.

b. Connect the ground lead of the signal generator to test stand FT-252-(*). Connect a .05- μ f capacitor in series with the output lead of the signal generator and connect the other end of the capacitor to the No. 6 pin of tube VT-171, used as a converter-oscillator. Set

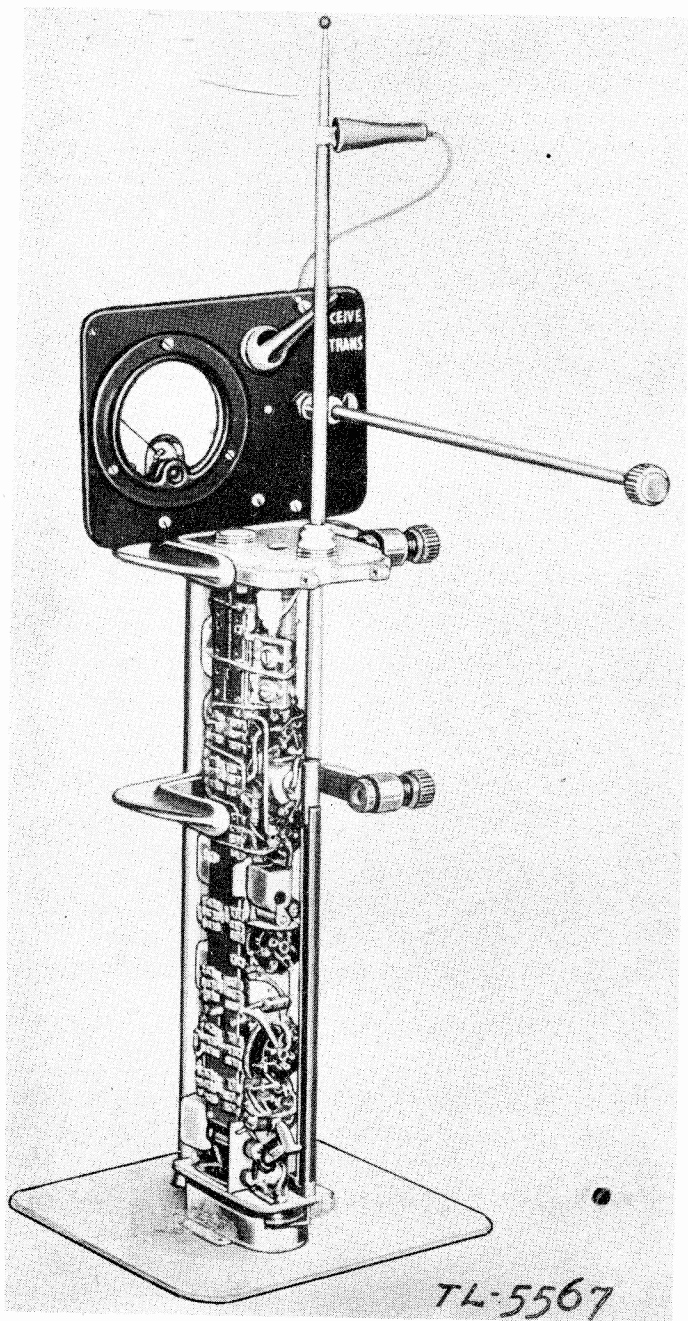

FIGURE 13.—Servicing set-up with test stand FT-252-(*).

the signal generator frequency accurately to 455 kc by means of frequency meter set SCR-211-(*). Set the MASTER SWITCH of the test unit to OUTPUT 0-60 V. A. C. position. Do not depress the press-to-talk switch. Adjust the generator output until a 10-volt reading is obtained on the output meter. Considerable generator output will be required when the set is badly out of alinement.

c. Adjust the trimmer on the second i-f transformer for maximum audio output. Do not grasp the test stand during i-f alinement. Reduce the generator output as the audio output increases above 10 volts. Next, peak the secondary on the first i-f transformer, and then peak the primary trimmer. After these adjustments have been made, put the chassis back into test case CS-81-(*), and aline the set as described in presetting receiver procedure, paragraph 58.

62. I-f alinement using test equipment IE-17-(*).—a. Be sure that the frequency of the REC (receiver) crystal is 455 kc higher than that of the TRANS (transmitter) crystal. The chassis may be left in the test case when using this method. The receiver crystal must be installed in the chassis and the transmitter crystal in the test unit I-135-(*).

b. If the presetting receiver procedure described in paragraph 58 has been followed, and no readable audio voltage has been obtained on the OUTPUT 0-60 V. A. C. position of the test unit meter, first make sure that a maximum r-f signal is being radiated. This can be assured by connecting a short length of wire to the R. F. OUTPUT terminal of the test unit and placing this wire close to the receiver antenna.

NOTE.—Test unit I-135-A does not have an R. F. OUTPUT terminal. The instructions furnished with the unit explain how to make this connection.

c. With the MASTER SWITCH of the test unit on OUTPUT 60 V. A. C. (modulate tester switch ON), adjust the second i-f secondary trimmer for maximum output, next the first i-f secondary trimmer, and the first i-f primary trimmer last. (See fig. 5.) All i-f trimmers are adjusted for peak output meter reading. As the i-f trimmers are alined, loosen the signal coupling to the receiver antenna so the maximum audio output reading of the meter is not over 10 volts. This is necessary to prevent overloading the receiver and consequent poor alinement of the i-f circuits. The above alinement adjustments must be performed very carefully for good results. Go over the alinement a second time.

d. After the i-f alinement adjustments have been made, complete the procedure by adjusting the receiver antenna adjustment screw and the receiver tank adjustment as described in paragraph 58g and h.

63. Testing batteries BA-37 and BA-38.—*a.* Use test equipment IE-17-(*) for this test, but be sure that the external heavy-duty batteries are *disconnected*. The radio set chassis *with both crystals in place* is mounted in the test case, connected to the test unit, and then placed in the test stand with antenna rod extended. The press-to-talk switch must be *in transmit position*. The MASTER SWITCH of the test unit should be OFF. Place radio set batteries BA-37 and BA-38 in the compartment of the test unit. Close and secure the compartment cover. (See fig. 7.) MODULATE TESTER switch must be OFF.

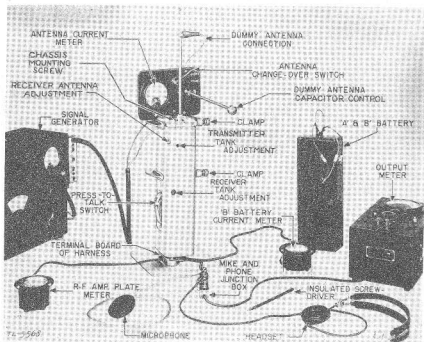

FIGURE 14.—Test equipment IE-15-A—set up.

b. Place the MASTER SWITCH on test unit in BA-37, O-3 V. D. C. position and observe the meter reading. Normal readings will be between 1.35 and 1.5 volts. If the voltage is less than 1.25 volts, the battery should be discarded and replaced with a new one.

c. Place the MASTER SWITCH on test unit in BA-38, O-150 V. D. C. position and observe the meter reading. *Be sure the set is in transmit position.* The normal meter readings will be between 75 and 103.5 volts. If the voltage is below 70 volts the battery should be discarded and replaced with a new one.

d. When it becomes necessary to discard battery BA-37 or battery BA-38 because of low voltage, both batteries in the radio set should be replaced at the same time. Batteries which are near the lower voltage limit may be used, but they will reduce the overall performance of the radio set.

64. Test equipment IE-15-A.—a. The purpose of this test equipment is identical to that of test equipment IE-17-(*). Test equipment IE-15-A consists of the following components:

- Test stand FT-252-A, including dummy antenna and r-f galvanometer
- Test case CS-81-(*)
- Milliammeter, O-50, d-c
- Milliammeter, O-15, d-c
- Harness
- Feedback capacitor

b. The following additional equipment is required when using test equipment IE-15-A:

- R-f signal generator
- Test set I-56-(*)
- Frequency meter SCR-211-(*)
- Battery supply (BA-40)
- Microphone
- Headset
- Insulated tuning screw driver
- Small screw driver

65. Use of test case CS-81-(*).—Since the tuning adjustment points of the radio set are inaccessible because of their locations on the chassis being covered by the case or housing, a special housing is required to contain the chassis while making these adjustments. (See fig. 14.) Test case CS-81-(*), used for this purpose, is similar to a chassis housing except for the holes that have been provided to permit access to the chassis adjustments. This permits tuning the set under conditions identical to those of normal operation. The tuning adjustments should not be made on the set without the test case housing around the chassis, because the set would become detuned when inserted into its regular housing. This detuning would result from the additional capacitance introduced into the circuit by the housing.

66. Use of test stand FT-252-(*).—This test stand contains clamps to hold the test case CS-81-(*), or the radio set chassis, a 50-milliamperere r-f meter to measure transmitter antenna current, and a receiver and transmitter dummy antenna consisting of a receive-transmit switch, a 56-ohm resistor, and a variable capacitor of 8 μf maximum capacitance.

67. **Test harness and meters.**—A special test harness cord supplied with the stand provides connections for the batteries, r-f amplifier plate current meter, total B current meter, audio output meter, earphone, and microphone. The schematic drawing of this harness is shown in figure 15. The 15-milliampere meter is used to measure the r-f amplifier plate current while the 50-milliampere meter is used to measure the total B battery BA-38 current. The terminal board attached to the harness provides a simple method of making the connections to the chassis.

68. **Use of test set I-56-(*).**—Since radio receiver and transmitter BC-611-(*), output is designed to operate into a high-impedance earphone, the output meter provided in test set I-56-(*), is un-

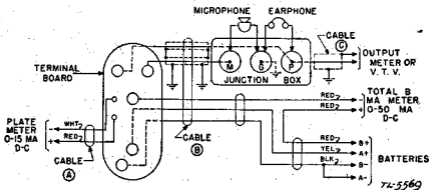

FIGURE 15.—Test equipment IE-15-A—harness connections.

satisfactory for alinement purposes because of its low internal resistance. This output meter has a resistance of only 4,000 ohms. A vacuum tube voltmeter with a minimum input impedance of 10 megohms would be preferable; however, the a-c voltmeter of the selective analyzer test set I-56-(*), makes a satisfactory output meter if the 50-volt a-c range is used. Since the meter sensitivity is 1,000 ohms per volt, 50,000 ohms is placed across the receiver output when the 50-volt range is used. No external blocking capacitor in series with the A-C output meter is necessary to prevent the B battery BA-38, voltage from reaching the meter, as one is contained in the receiver circuit. The output meter leads of the test harness are fitted with pin jack tips, so they can be plugged into the voltmeter.

69. **Presetting frequency with IE-15-A.**—To cover the authorized range of frequencies from 3.5 to 6.0 megacycles, individual matched sets of antenna coils, r-f tank coils, and crystals are avail-

able. Each coil is marked with its frequency and part number so that errors of coil selection will be minimized.

NOTE—The coils supplied with radio set SCR-536-A are not preset in one frequency. Instead, each is adjustable over the small frequency range marked on the coil. The frequency range of each is indicated in chart I. The coils manufactured for radio sets SCR-536-B and SCR-536-C are identical but have been preset to the frequency indicated on each.

a. To preset the operating frequency of radio receiver and transmitter BC-611-(*), obtain a coil and crystal equipment of the desired frequency. The coil and crystal equipment comes in an individual carton marked with the frequency and contains the transmitter and receiver crystals, the antenna coil, and the r-f tank coil. The antenna coil is larger and of different shape than the r-f tank coil. Its base connections also differ, so it is impossible to put the coils in the wrong sockets. Both coils are of the plug-in type. (See figs. 8 and 10.)

b. Remove the chassis of radio receiver and transmitter BC-611-(*) from its housing. To do this, unlatch the bottom cover of the housing and remove the batteries. Place them aside for test. Disconnect the microphone and earphone plugs from the terminal board on the end of the chassis by gently lifting them. Remove the screw in the top cover of the housing; the chassis then will slide out of the bottom end of the housing.

70. Changing coils and crystals.—a. *Antenna coil.*—Remove the plug-in antenna coil by carefully lifting it out of its socket. See figure 10 for its location. In its place insert another coil of the desired frequency.

b. *R-f tank coil.*—To remove, loosen the screw holding down the coil-retainer spring on top of the coil. (See fig. 9.) Swing the spring free of the coil. The coil then can be lifted out of the socket. When replacing with another coil of the desired frequency, carefully fit the coil over the two pins projecting up from the socket so that the pins fit into the holes in the coil form, and the coil adjustment shaft fits into the hole in the socket. Gently press the coil into the socket, replace the coil-retainer spring on top of the coil, and tighten the screw holding the spring.

c. *Crystals.*—The crystals are mounted in plug-in type holders. (See fig. 10.) To remove a crystal, lift up the clamp located on top of the crystal holder. This clamp pivots on a stud fastened to the chassis. Place a small screw driver between the crystal holder and the socket and gently pry it up. To remove the other crystal holder, the same procedure is followed. Select a transmitter and a receiver crystal holder of the desired frequency. (The frequency of the trans-

mitter crystal will be the same as that of the coils, while the receiver crystal will be 455 kc higher in frequency.) Insert the receiver crystal holder in the crystal socket marked REC. It should be inserted so that the frequency printed on the metal side faces out and the arrow on the holder points in the same direction as the arrow on the socket. Place the transmitter crystal in the socket marked TRAN. in exactly the same way. The printed metal side of the holder should show through the opening in the chassis.

CHART I.—Frequency range of coils for radio set SCR-536-A

R-F Tank	Frequency (in kc)	Antenna	Frequency (in kc)
C-370.....	3500-3825	{ C-358.....	3500-3675
		{ C-359.....	3675-3825
C-371.....	3825-4225	{ C-360.....	3825-4025
		{ C-361.....	4025-4225
C-372.....	4225-4625	{ C-362.....	4225-4425
		{ C-363.....	4425-4625
C-373.....	4625-5075	{ C-364.....	4625-4825
		{ C-365.....	4825-5075
C-374.....	5075-5500	{ C-366.....	5075-5300
		{ C-367.....	5300-5500
C-357.....	5500-6000	{ C-368.....	5500-5775
		{ C-369.....	5775-6000

71. **Setting up test equipment IE-15-A.**—*a.* Connect the four wires of the harness marked A+, A-, B+, B-, to their proper terminals on the batteries. Connect the two wires marked VT-174 PLATE MA to the 15-milliamperè meter; connect the two wires marked TOTAL B MA to the 50-milliamperè meter; and connect the two unmarked wires to the 50-volt a-c range of the selective analyzer unit of test set I-56-(*). Connect the earphone to the terminals marked G and P on the junction box attached to the harness. The earphone lead connected to the braided shield should connect to the G (ground) terminal.

b. Place the chassis into the test housing. The chassis must be inserted into the test housing through the bottom, as is done when inserting the chassis into its own housing. Take care that the chassis fits between the guides provided for it in the housing. It should not be necessary to force the chassis. If it is, withdraw the chassis and check to see that no parts are catching on the housing or that the chassis has not jumped the guides. Slip the top cover over the antenna rod and fasten the chassis to it with the 8/32 mounting screw. The chassis then will be held securely in the test housing. *Now remove the plate current meter jumper from the terminal board at the end of the chassis.*

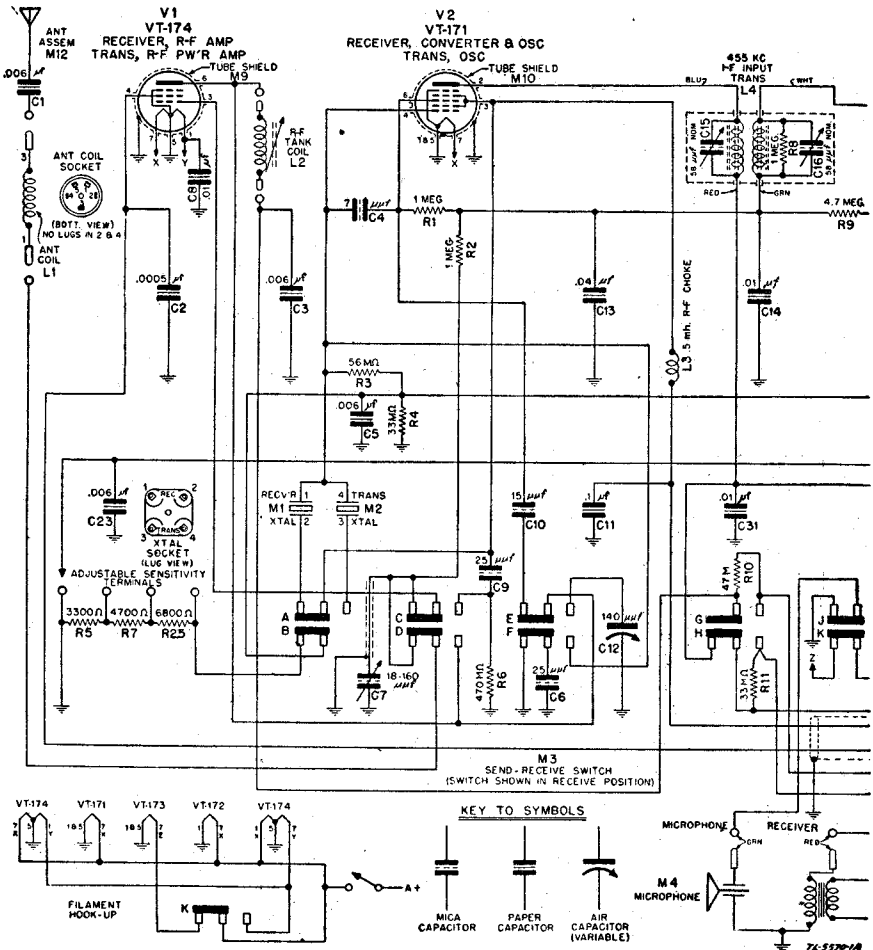

FIGURE 16.—Radio receiver and transmitter BC-611-A—schematic diagram.

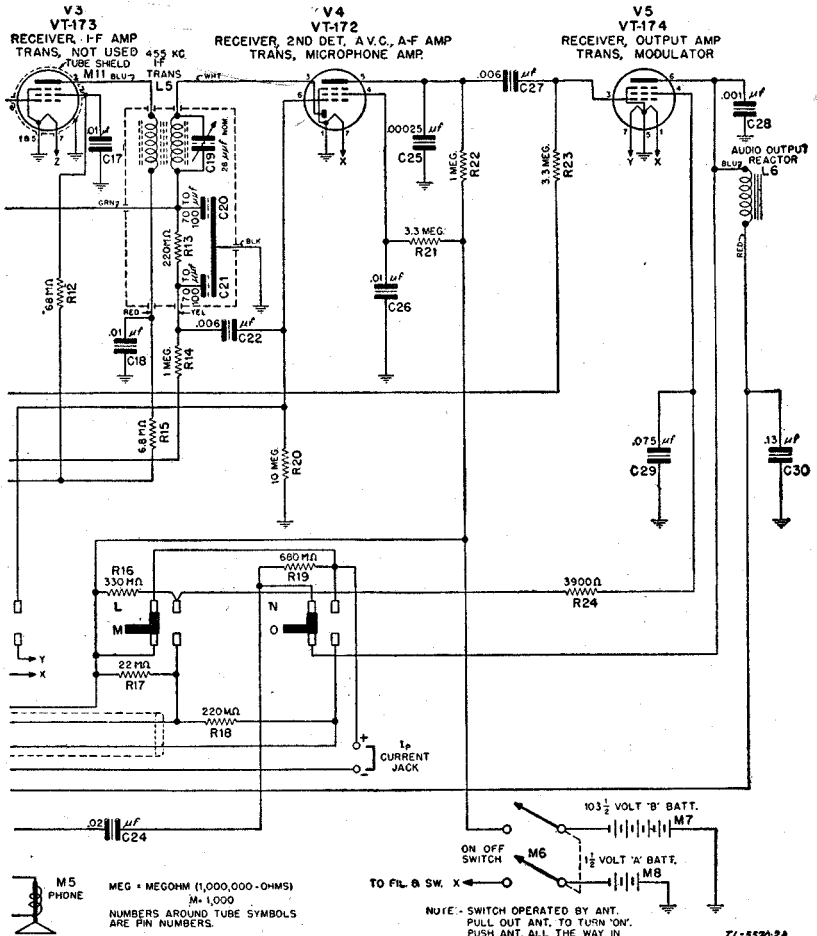

FIGURE 16.—Radio receiver and transmitter BC-611-A—schematic diagram—Continued.

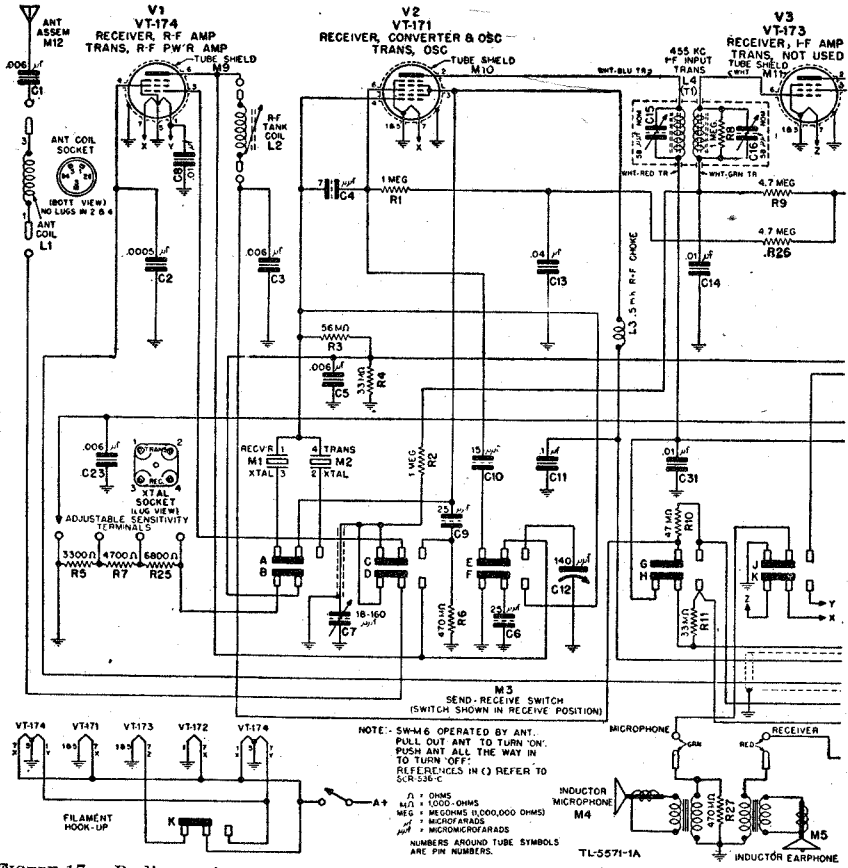

FIGURE 17.—Radio receiver and transmitter BC-611-B and BC-611-C—schematic diagram.

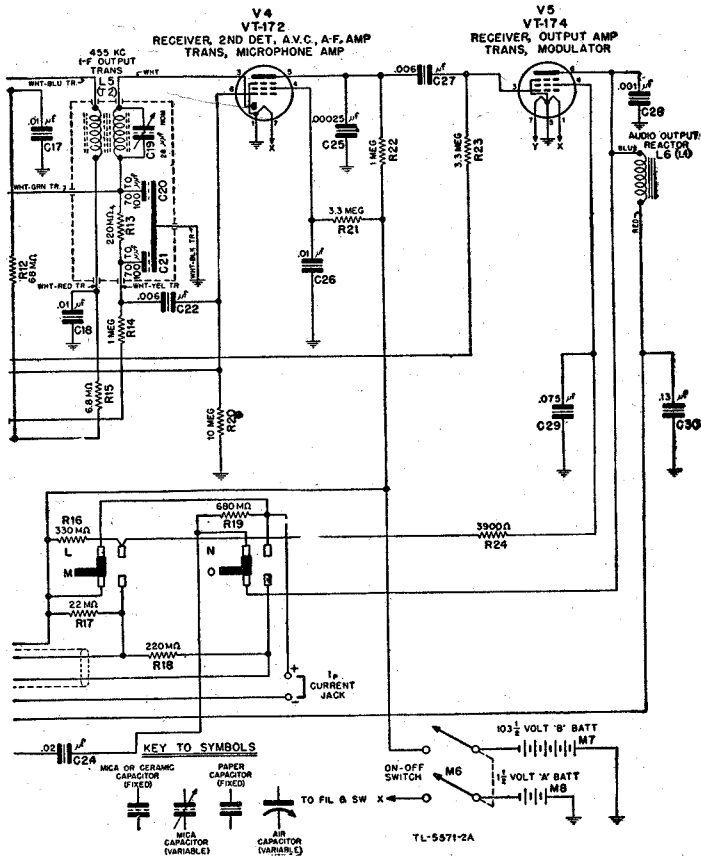

FIGURE 17.—Radio receiver and transmitter BC-611-B and BC-611-C—schematic diagram—Continued.

Caution: Do not misplace the jumper.

c. Attach the terminal board of the harness to the terminal board of the chassis, so that the two small pins on the harness terminal board fit into the plate current meter jacks, and so that the two large locking pins, one on each end of the terminal board, fit into the holes provided for them. Lock the two terminal boards together by a sideward movement of the levers attached to the locking pins.

d. Next clamp the test housing into the test stand FT-252-(*) with the antenna end up, and the housing in such position that the change-over switch is opposite the left side of the operator, as he faces the stand. (See fig. 11.) The upper clamp should grasp the housing on the edges of the top cover. The lower clamp should not be made too tight as the pressure may crack the housing.

e. The signal generator used should be modulated 30 percent by a 400 to 1,000 cycles per second tone and should be accurately set to the carrier frequency of the radio receiver and transmitter BC-611-(*). The signal generator frequency must be checked with an accurate frequency meter, such as SCR-211-(*).

72. Presetting receiver with IE-15-A.—a. Extend the radio set antenna rod to its full length, 39 inches above the top cover of test case CS-81-(*). This will turn on the radio set. Do not press the press-to-talk switch on the test case during the receiver presetting adjustments.

b. Connect the ground lead of the r-f signal generator to the test stand, but leave the output lead of the signal generator unconnected. The r-f input to the receiver will then be the pick-up on the antenna. The generator output should be adjusted for a reading of approximately 10 volts on the 50-volt a-c range of the output meter. If the receiver is badly out of alignment it may be impossible to get this output reading or any at all; in such a case follow procedure in paragraph 74.

c. Grasp the test case with one hand during all of the following adjustments.

d. The location of the receiver tuning adjustments is shown in figures 11 and 14. With the insulated screw driver, turn the *receiver antenna adjustment* screw clockwise. Notice the effect of this adjustment on the output meter reading. If the meter reading increases, continue to tighten the screw until a maximum reading is obtained. If reading decreases, turn the screw counterclockwise until a maximum reading is obtained. Be careful not to tighten the screw after it begins to turn hard as the threaded base of the trimmer will be stripped. The setting of the screw for maximum output should fall somewhere between the point of hard turning and that of minimum pressure.

If a maximum point is not reached in these limits of the screw adjustment, try another antenna coil. If the set appears to be badly out of alignment, follow procedure in paragraph 74.

NOTE.—Be sure that the r-f signal is not strong enough to cause overloading of the receiver. If this condition exists, adjustment of the receiver antenna adjustment screw will have little or no effect on the output reading. Best results will be obtained if the r-f output from the signal generator is adjusted, so that the output meter reading on the 50-volt a-c scale does not exceed 10 volts, although satisfactory results may be obtained with readings up to 20 volts.

e. Using the insulated screw driver, turn the *receiver tank adjustment screw* for maximum output, using the same method employed in paragraph 72d.

NOTE.—This screw, which is made of bakelite, fits into a powdered iron core which is threaded. The movement of the screw changes the position of the core in the coil. If the screw is turned too far clockwise, the core will ride up against the screw head, and the threads in the core will be stripped. If the screw is turned too far counterclockwise, the core will come in contact with the coil socket and again further turning will strip the core threads. The screw setting for maximum output should fall somewhere between these two limits of adjustment. If it does not, a wrong tank coil may be in the set. This completes the receiver adjustments.

73. Presetting transmitter with IE-15-A.—a. Grasp test case and operate press-to-talk switch with one hand during all the following presetting operations to the transmitter:

(1) Using the small screw driver, adjust the *transmitter tank adjustment screw* for minimum current reading on the 15-milliamperemeter. The normal reading is approximately 7 milliamperes. See figures 12 and 14 for location of the *transmitter tank adjustment screw*. Release the press-to-talk switch.

(2) Telescope the upper three sections of the antenna rod, leaving only the bottom or fourth section fully extended from the housing. Next, clip the *dummy antenna connection* to the upper part of the antenna rod. (See fig. 12.) Set the *antenna change-over switch* on the panel of test stand FT-252-(*) to TRANS. position.

(3) Connect the microphone provided with the test set to the M and G terminals of the test harness. The braided lead goes to the G terminal.

(4) Grasp the test case and depress the press-to-talk switch again. Using the insulated shaft extension, adjust the *dummy antenna capacitor control* for minimum current reading on the 15-milliamperemeter. The reading should be approximately 7 milliamperes. This adjustment of the dummy antenna capacitance for minimum power amplifier plate current is necessary to compensate for the change in antenna capacitance due to telescoping the upper three sections of the

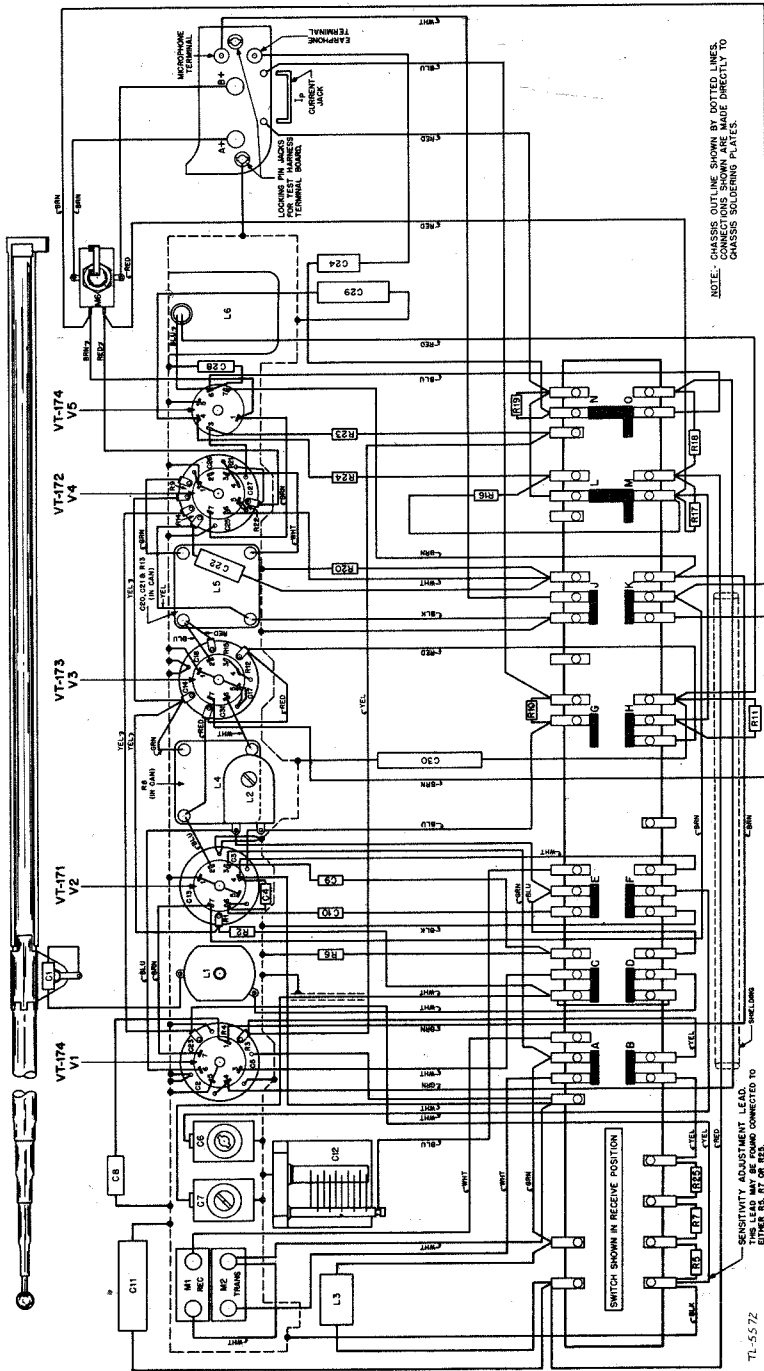

NOTE: CHASSIS OUTLINE SHOWN BY DOTTED LINES. CONNECTIONS TO CHASSIS MADE DIRECTLY TO CHASSIS SOLDERING PLATES.

Figure 18.—Radio receiver and transmitter BC-611-A—practical wiring diagram.

TL-5572

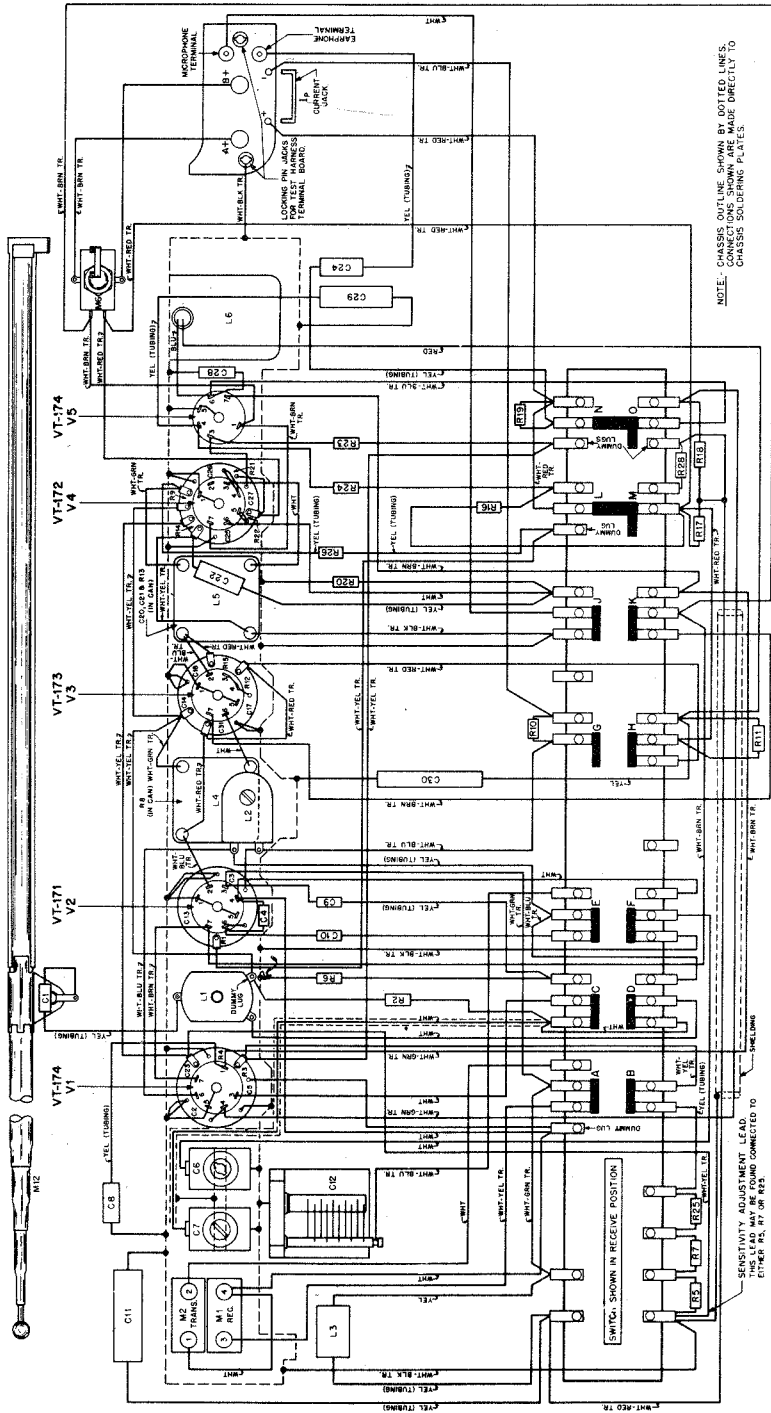

Tl-5573

References in parentheses () refer to SCR-536-C only.

FIGURE 19.—Radio receiver and transmitter BC-611-B and BC-611-C—practical wiring diagram.

59 The two leads have been removed from the dummy lug at Section "L" and moved to dummy lug between Sections "G" and "J" on the receive-transmit switch.

antenna rod. Observe the reading on the *antenna current meter* on test stand FT-252-(*). It should be from 15 to 24 milliamperes, representing the unmodulated antenna current.

(5) (a) Modulate the transmitter by whistling a steady note into the microphone, and watch the antenna current meter on the stand. It will be found that the meter reading increases. Keep whistling until the pointer on the meter reaches its highest position, then note the reading. Be sure to whistle loud enough to cause the meter reading to rise. The meter reading should increase 15 to 20 percent over the reading obtained when not whistling into the microphone. For example, assume that the current when not whistling is 20 milliamperes and when whistling is 24 milliamperes. The increase in current is then:

$$24 - 20 = 4 \text{ milliamperes}$$

the percentage increase will be:

$$4/20 \times 100 = 20 \text{ percent}$$

(b) Another method which can be used is to divide the current when whistling by the current when not whistling. The answer should be greater than 1.15. For example, take the values of r-f current previously given. Dividing the modulated current by the unmodulated current gives $24/20 = 1.2$.

b. If less than 15 percent increase is obtained, check the crystal for activity; and also check the modulator, r-f amplifier, and oscillator tubes for output. Be sure that the battery voltage under operating conditions is at least 75 volts.

c. This completes normal frequency presetting adjustments. Remove the chassis from the test case, replace it in the radio set housing, and reconnect the microphone and earphone. *Be sure to replace the plate current meter jumper.* Reinstall the A and B batteries, making certain that the positive (+) ends face out. Close the cover, move the latching bolt into place, and tighten the knurled nut. The set is now ready for operation.

74. I-f alinement.—If the i-f transformers are badly out of alinement, it may be impossible to get a carrier frequency signal through the receiver as outlined in the presetting receiver procedure. For such a condition, the i-f transformers should be realined. Use the following procedure:

a. Remove the chassis from the test case and fasten it to the top cover of the housing with the mounting screw. Then place the chassis in the test stand in the same relative position as when in the test hous-

ing, and hold it there by gripping the housing cover with the upper clamp of the test stand. (See fig. 13.)

b. Connect the ground lead of the signal generator to the test stand FT-252-(*). Connect an .05- μ f capacitor in series with the output

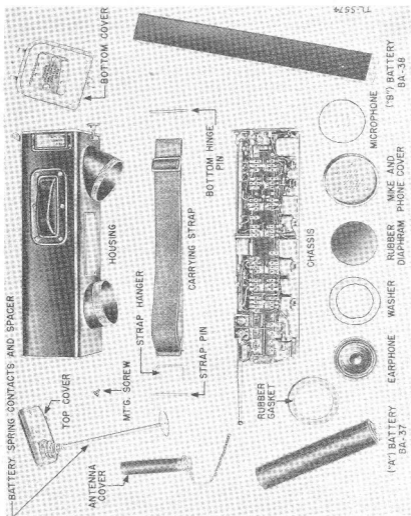

FIGURE 20.—Radio receiver and transmitter BC-611-(*),—disassembled.

lead of the signal generator, and connect the other end of the capacitor to the No. 6 pin of the tube VT-171. Set the signal generator frequency to 455 kc and then adjust the generator output until a 10-volt reading is obtained on the 50-volt a-c range of the output meter. Considerable generator output will be required when the set is badly out of alinement.

c. Adjust the trimmer on the second i-f transformer for maximum output. Reduce the generator output as the output increases above 10 volts. Next peak the secondary trimmer on the first i-f transformer, and then peak the primary trimmer. After these adjustments have been made, put the chassis back into the housing and align the set as given in the presetting receiver procedure. (See fig. 5.)

75. Checking for image frequency.—*a. General.*—When setting the generator frequency, care must be taken that the frequency is that of the signal to be received and not the *image frequency*, which is exactly 910 kc higher than the carrier frequency. For example, a unit aligned for proper operation at 4,000 kc will have an image response at 4,910 kc, while one which operates on 5,000 kc will have an image response at 5,910 kc.

b. Image frequency check.—In checking for proper operation (in regard to image reception) take the following steps:

(1) Completely align receiver to the carrier frequency. Note the signal generator dial reading.

(2) Refer to the calibration charts of the signal generator (or to its dial if it is directly calibrated) and estimate the dial reading for a frequency of 910 kc above that in the step (1) above.

(3) Increase signal generator output to 1,000 times its output necessary to produce 10 volts across the earphone and the output meter.

(4) Rotate the signal generator dial to the dial reading ascertained in step (2) above. A signal should now be heard. Rotate the dial for a maximum signal as indicated on the output meter. Adjust the generator output by means of the attenuator so that the output meter across the earphone indicates exactly 10 volts. Note the reading necessary to produce 10 volts. If this image frequency sensitivity is divided by the carrier frequency sensitivity, the resulting number should never be less than 200. If no signal is heard at 910 kc above the carrier frequency, it is a certainty that the receiver is not correctly aligned, and the unit should be realigned as outlined in paragraph 72.

76. BC-611-(*) as signal generator.—*a. General.*—(1) If a situation should arise in which it is necessary to change the frequency of radio receiver and transmitter BC-611-(*), and no signal generator is available, it is possible to preset the frequency provided another radio receiver and transmitter BC-611-(*) operating at the same carrier frequency is available.

(2) If another such set is available, but is not of the correct carrier frequency, it can be made to operate at the correct frequency by inserting the correct crystal and proper antenna and tank coils.

(3) In order to preset one set, it will be necessary to convert the other set into a modulated signal generator. This may be done by simply putting the set in the transmit position and placing a buzzer near the microphone; if a buzzer is not available, the carrier can be self-modulated by converting the audio amplifier in the set into an audio oscillator. This circuit change can be made easily by placing a capacitor of $100\mu\text{mf}$ between the microphone plug and the plate current meter jack on the terminal board of the chassis. This capacitor will provide enough feedback between the input and output to cause the audio amplifier to go into oscillation. When the radio set is put into the transmit position, an audio note will be heard in the earphone of the unit and a signal will be radiated, modulated by this audio tone. A special capacitor designed for this purpose is supplied with test equipment IE-15-A. (See figs. 21 and 22.) To simplify connections, one lead of the capacitor is tipped with a spade lug and the other lead is tipped with a plate current meter jumper. The spade lug has a small hole in it for the microphone plug and is designed to fit between the microphone plug and the microphone jack on the terminal board. The spade lug is painted green to identify it with the microphone plug, which is marked with a green spot.

(4) The plate current meter jumper connected to the capacitor replaces the plate current jumper in the set.

b. Setting up the signal generator.—Procedure for converting radio receiver and transmitter BC-611-(*) into a modulated signal generator is as follows:

(1) First remove the chassis from the housing of the set.

(2) Select a crystal of the exact frequency to which the other set is to be preset, and place it in the transmitter crystal socket. Select another crystal which is 455 kc higher in frequency and place it in the receiver crystal socket. Select the proper antenna and tank coils and insert them into their respective sockets.

(3) Place the set into the test housing and connect the test harness as described in paragraph 71.

(4) With the antenna rod fully extended, grasp the test case and put the set in the transmit position and with a small screw driver adjust the transmitter tank adjustment screw for minimum reading of the plate current meter.

(5) Disconnect the harness from the chassis and remove the chassis from the test housing. *Do not forget to replace the plate current meter jumper.* Put the set into its own housing and connect in the audio feedback capacitor. (See figs. 21 and 22.) Place the spade lug of the capacitor lead between the microphone jack and the micro-

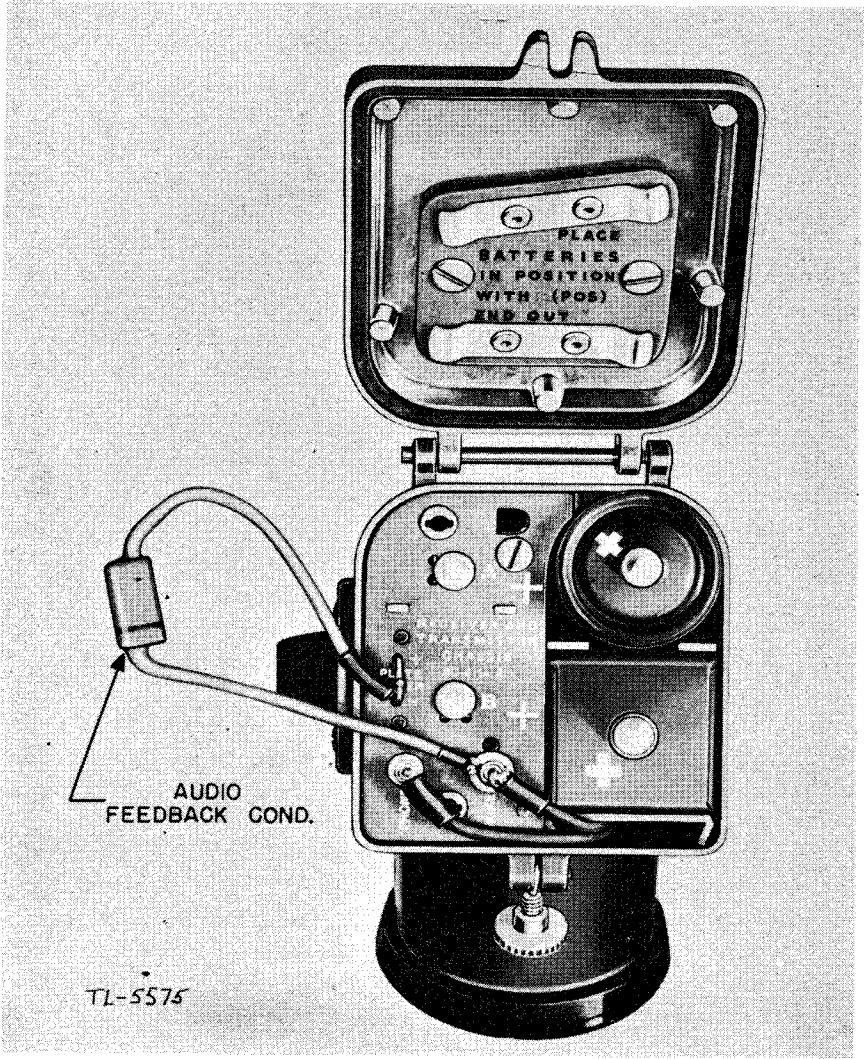

FIGURE 21.—Connections for self-modulation.

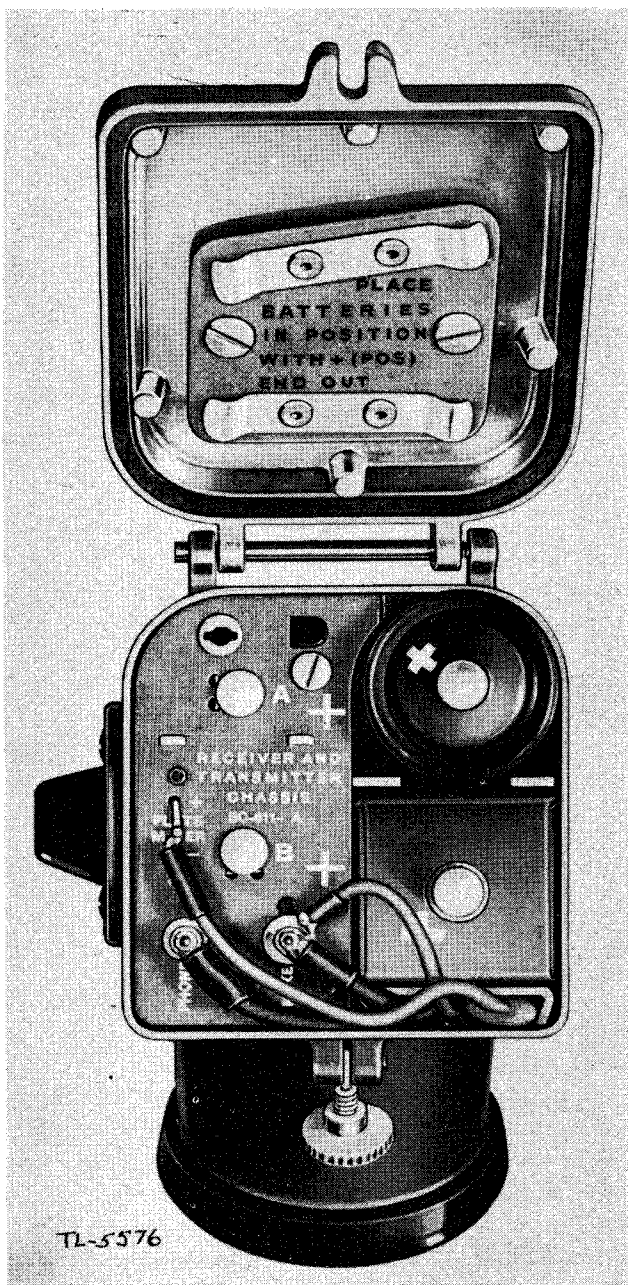

FIGURE 22.—Placement of audio feedback capacitor.

phone plug. Remove the plate current meter jumper and replace it with the jumper attached to the other capacitor lead. Replace the batteries and place the capacitor into the space between the housing wall and the B battery spacer and then close the bottom cover. Check the set to see that it is oscillating by operating the press-to-talk switch and listening for an audio tone. The set is then ready for use as a modulated signal generator.

c. Presetting the set.—(1) Remove the chassis from the housing of the set to be preset and insert the correct crystals and coils.

(2) Put the chassis into the test housing and attach the test harness; then extend the antenna to its full length. Do not connect the dummy antenna.

(3) Tie down the press-to-talk switch of radio receiver and transmitter BC-611-(*) being used as the signal generator, with a piece of twine or wire, place it about 20 feet away from the receiver to be preset and extend its antenna.

(4) With the set in the test case in the receive position, adjust the antenna trimmer for maximum audio output. If the signal picked up is too strong, (which will show up in a noncritical adjustment of the receiver antenna adjustment screw) the signal radiated from the set used as the signal generator can be reduced by telescoping sections of the antenna rod. (Because the bottom section of the antenna rod operates the power switch be careful not to turn off the set.) If this does not reduce the signal sufficiently, place the set used as the signal generator on the ground with its antenna in a horizontal position and pointing away from the set being adjusted.

(5) Next adjust the receiver tank adjustment screw for maximum audio output. The receiver is now properly aligned and the radio receiver and transmitter BC-611-(*), used as a signal generator, can be turned off.

(6) To preset the transmitter, place the set in the transmit position and adjust the transmitter tank adjustment screw for minimum plate current.

(7) Collapse the upper three sections of the antenna rod and connect the dummy antenna to the top of the rod. Connect the microphone to the M and G terminals of the junction box. Then adjust the dummy antenna capacitor control for minimum plate current. Whistle into the microphone and check the antenna current increase due to modulation as given in paragraph 73.

77. Replacement of parts.—*a. Antenna rod.*—(1) To replace the antenna rod, first the chassis must be removed from the case. The antenna rod fits into an insulated guide which is fastened to the chassis at the terminal board by a machine screw. The antenna rod

in the extended position is supported by a metal clamp attached to a polystyrene base. At the side of the clamp, where it is fastened to the polystyrene base, are three wiper contacts which grip the rod tightly. It is through these wiper contacts that the electrical contact to the antenna rod is made. An insulated plug in the bottom end of the antenna rod operates the toggle switch on the chassis.

(2) To remove the antenna rod, remove the screw which holds the antenna guide to the terminal board. Then gently bend the terminal board away from the antenna guide so that the plug at the end of the guide disengages from the hole in the terminal board. *Exercise the greatest care in this operation as it is possible to tear the terminal board loose from its fastenings.* Then with the guide unfastened, the antenna rod is withdrawn from the metal clamp.

(3) To replace the antenna rod, slip the antenna guide over the bottom section of the rod. Pass the antenna rod through the antenna guide ferrule and seat the ferrule at the top of the guide. Insert the tip of the antenna rod into the antenna clamp and push the rod through the clamp gently, until the top of the antenna guide comes in contact with the clamp. The antenna guide is then oriented so that the insulated end plug on the antenna rod will engage the lever on the power switch. Then very carefully bend the terminal board back slightly; just enough to permit the plug at the end of the guide to seat in the hole in the terminal board. Replace the fastening screw.

b. Replacement of resistor-capacitor cups.—(1) There are four resistor-capacitor containers which are called cups on the bottom of the chassis. These cups fit around the tube sockets and it will be necessary to unsolder the wires from the tube socket as well as the cup before removing. The cups are fastened to the tube sockets by cement, and must be pried loose from the socket by a screw driver or a knife. The cup will be broken in the process.

(2) Each cup has a part number marked on it as well as a schematic drawing of the condenser and resistor connections. When replacing a cup, be sure that the new cup has the same part number as the old one. As a great number of wires will have to be unsoldered, it will be found helpful to put on paper a simple description of each wire removed and the point to which it connects. Reference to the cup diagrams shown in figure 23 also will be found helpful. The old cement should be scraped off the socket base before cementing the new cup in place. The new cups should be placed on the chassis so that the part number on the cup faces the back of the chassis, considering the press-to-talk switch side to be the front.

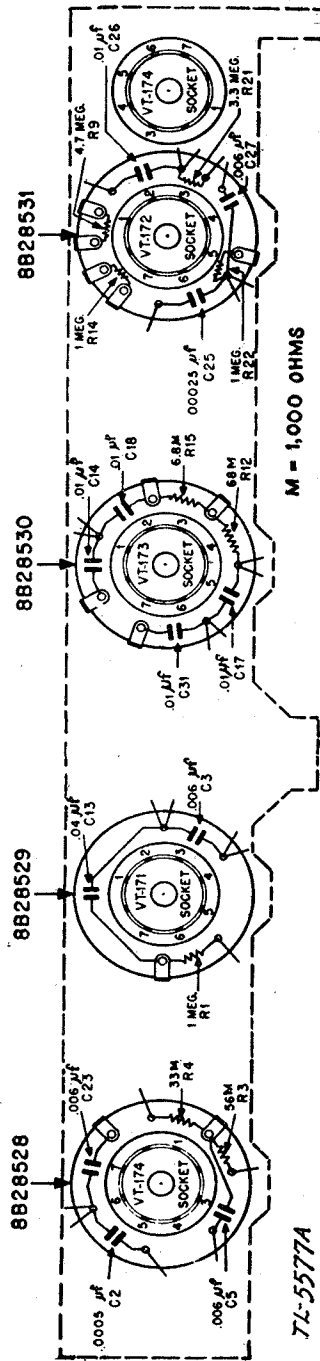

Figure 23.—Resistor-capacitor cups—schematic diagram.

7L-5577A

Caution: When soldering connections to a new cup be careful not to apply too much heat. The cup may be damaged beyond repair if this precaution is not observed.

c. To replace an i-f transformer.—Disconnect the transformer wires, and remove the clamps holding the transformer shield can to the chassis. Make a note of the transformer position so that the transformer wires can be put back in the same position as they originally were; otherwise, oscillation may result. The position of the transformer with respect to the trimmers in the top of the can should also be considered, so that the trimmers can be reached through the openings in the test housing when aligning the set. Make sure the i-f unit clamps are not bent so that they come in contact with the switch, a condition which will result in a short circuit.

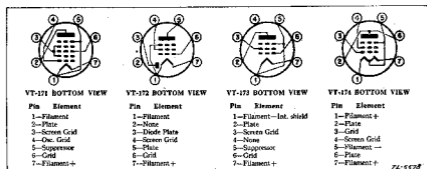

FIGURE 24.— Tube base connections.

d. To remove an eyelet.—As most of the parts are fastened to the chassis with eyelets, removal of the eyelets is necessary for the replacement of these parts. A simple and effective way to remove an eyelet is to place a drill point of a diameter larger than the eyelet in a vise with the tip end up. Place another drill point of a similar diameter in a brace. Put the eyelet to be removed over the drill point in the vise, then apply the brace to the other side of the rivet and drill it out. Take care to drill out only enough material to remove the rolled over edge of the eyelet. Do not drill through the chassis. This will enlarge the hole and make the replacement of a new eyelet difficult.

e. To replace power switch.—To replace the power switch it will be necessary to first remove the a-f choke and the two tubular capacitors next to the switch. Next remove the nut holding the switch to the chassis and then remove the wires to the switch. The switch now can be removed from the chassis by patient maneuvering.

78. Trouble location and remedy.—The following are possible troubles and their remedies:

a. Excessive r-f amplifier plate current in the transmit position.—

(1) If the r-f amplifier grid excitation (the r-f voltage applied to the amplifier grid) is low, insufficient bias voltage will be developed across the grid resistor R_6 , and the plate current will be excessive. Low grid excitation may be caused by a poor crystal or a weak or burned out oscillator tube. Also, no excitation would occur if the coupling capacitor C_5 were open or the oscillator were not functioning. See chart II for transmitter characteristics.

(2) High plate current might be caused by an improper r-f amplifier tank coil. An incorrect coil will show up in the inability to get a dip in the plate current reading of the r-f amplifier tube when tuning this stage.

(3) High plate current could be caused also by short-circuited turns in the r-f amplifier coil. The effect would be the same as when using an incorrect coil. A leaky or short-circuited coupling capacitor C_5 would also cause excessive plate current.

CHART II.—Chart of average transmitter performance characteristics

Test	Average	Minimum
R-f current:		
Unmodulated.....	18 ma (r-f power: 18.1 mw).	15 ma (r-f power: 12.6 mw).
Modulated.....	20.5 ma (r-f power: 25.53 mw).	17.5 ma (r-f power: 17.0 mw).
Modulation capability.....	Over 50 percent.	Over 50 percent.
A battery BA-37:		
Voltage.....	1.4 volts.....	
Current.....	280 ma.....	
B battery BA-38:		
Voltage.....	95 volts.....	
Current.....	30 ma.....	

NOTE.—All values taken with chassis in test case C8-S1-(*).

b. Oscillator does not function (no reception and transmission).—To check for operation of the oscillator, place a d-c voltmeter across R_4 ; a reading should be obtained if it is functioning. (See fig. 25 and chart III.) Besides the common reasons for oscillator inoperation such as part failure, a weak crystal, low battery voltages, etc., inoperation can also be caused by defective switching. If in pressing the press-to-talk switch, the moving blade of switch section A does not make contact with the switch lug connected to the transmitter crystal M_2 at the same time or before the moving blade of switch section M short-circuits resistor R_{11} , the energy pulse necessary to start crystal activ-

ity will not reach the crystal and the oscillator will not function. As a result of the high screen voltage and no bias, the tube VT-171 will become paralyzed. To remedy this trouble, move the lug on switch section A connected to the transmitter crystal M_2 so that it does make

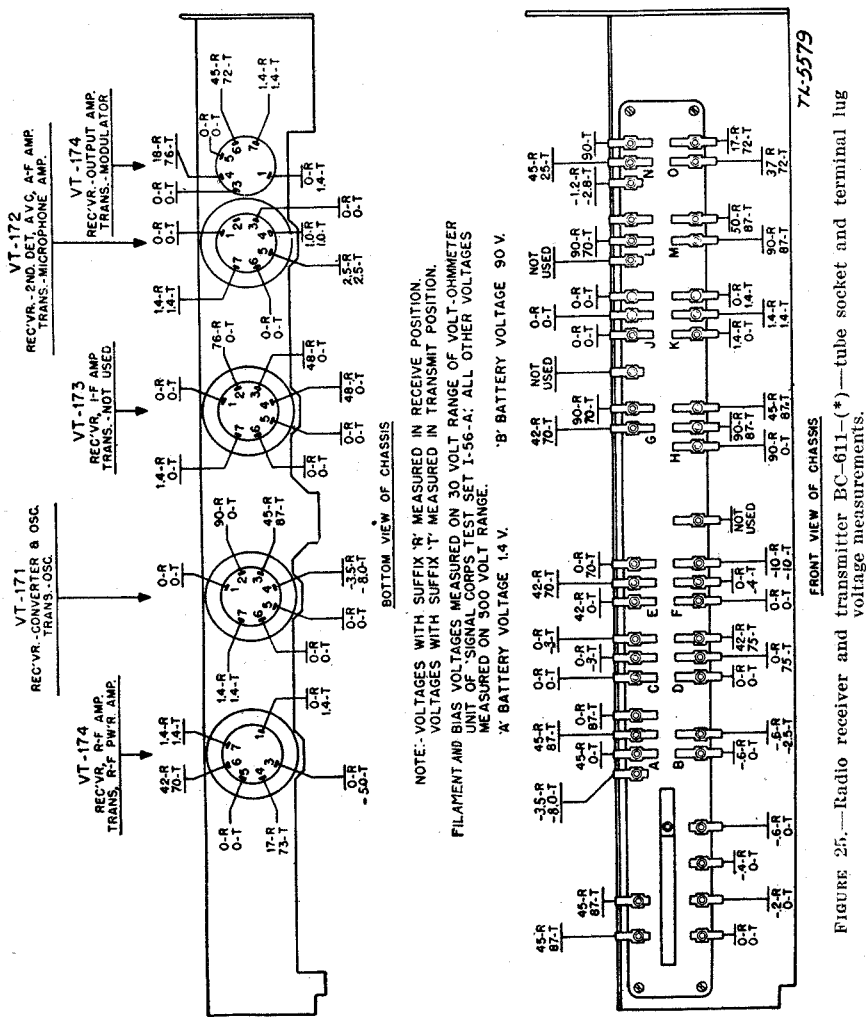

74-5779

FIGURE 25.—Radio receiver and transmitter BC-611-(*).—tube socket and terminal lug voltage measurements.

contact at the same time or before switch section M short-circuits resistor R_{17} . Also replace the tube.

c. *Audio oscillation in transmit position.*—(1) If the r-f amplifier tube VT-174 becomes inoperative, the load offered to the modulator tube is removed. The plate load of the modulator tube then will be the impedance of the modulation choke, which is high. Under this condi-

tion, sufficient coupling exists between the input of the audio amplifier and the output of the modulator to cause oscillation.

(2) Failure of the r-f amplifier tube VT-174 to operate can be caused by an open filament, gas in the tube, or loss of vacuum due to a crack in the glass. A cracked glass or gas in the tube will be indicated by a milky color near the exhaust tip of the tube.

d. Noise due to regeneration.—(1) A small amount of regeneration in the receiver is permissible, as it increases the selectivity and sensitivity of the receiver; however, because tubes of the same type vary somewhat in their gain characteristics, excessive regeneration may occur when tubes are changed in the receiver. Excessive regeneration results in a high circuit noise level, and in extreme cases causes oscillation. Regeneration is caused by coupling between circuit elements due to close spacing of parts on the chassis.

(3) The solution to this problem is to reduce the sensitivity of the receiver to a value which permits an allowable noise level. Provision for reducing the sensitivity of radio receiver and transmitter BC-611-(*) for cases of excessive regeneration is provided for by an adjustable bias arrangement. The three resistors R_{25} , R_7 , and R_8 , connected across the oscillator grid leak resistor R_4 , provide this adjustable bias arrangement. The lead connecting the detector load resistor R_{14} to the bias point should be moved one step up on the voltage divider to decrease the sensitivity. This adjustment will increase the bias on tubes V_1 , V_2 , and V_3 . Normally, this lead is grounded, but for sets of abnormal sensitivity will be found connected to one of the taps on the divider. The lead should be connected to the lowest point on this divider which provides a satisfactory noise level.

e. Sensitivity control adjustment.—(1) If after the proper alignment of a receiver it is found that the sensitivity is greater than 7 microvolts for a 15-volt output reading on the 50-volt a-c scale of the output meter, or 6 microvolts for a 20-volt reading on a vacuum-tube-voltmeter type output meter, adjustment of the sensitivity control is recommended. This adjustment, however, should be made only after checking the receiver to see that the lack of sensitivity does not result

from weak tubes, low battery voltage, or circuit failures. Charts IV and V give receiver performance figures.

(2) The sensitivity of the receiver is controlled by an adjustment of the grid bias on the r-f amplifier, mixer, and i-f amplifier tubes. The adjustable bias is obtained by means of the voltage divider made up of resistors R_6 , R_7 , and R_{25} . To increase the sensitivity of the receiver, the bias should be reduced. The reduction in bias is accomplished by moving the wire connecting resistor R_{14} to the voltage divider closer to the ground end of the divider. Minimum bias and greatest sensitivity will be obtained when this lead is connected to ground. Additional information on the sensitivity control is given in 78d (2).

f. Tube trouble.—(1) Tubes which have lost their vacuum because of a crack in the glass will usually have a milky color near the exhaust tip or base. The cracks are often plainly visible at the base of the tube.

(2) To avoid breaking tubes when removing them for inspection, remove the tube by inserting a rod through the metal tube in the center of the tube socket on the bottom of the chassis and by gently forcing the tube out. Be sure to remove the locking clip on top of the tube before forcing the tube out of its socket.

g. Loose or tight adjustment of antenna trimmer.—A very loose or very tight adjustment of the receiver antenna adjustment trimmer in the receive position indicates an incorrect antenna coil.

h. Loose connections.—(1) Some units may occasionally develop a loose connection. This is the condition where a set becomes noisy when rapped gently. Loose connections most commonly occur when two metallic conductors momentarily break the contact they are expected to maintain. This may happen between the sections of the antenna rod, between batteries and their contacts, internally in tubes, or in some cases, a poorly soldered connection.

(2) If a unit does develop a loose connection, the circuit elements at fault may be located by gently tapping at various places on the unit with the insulated handle of a screw driver. The noise becomes louder as the loose connection is neared.

CHART III.—Point-to-point d-c voltage measurements

Component	Receiver	Transmitter	Volt-meter range	Component	Receiver	Transmitter	Volt-meter range
R ₁ -----	0	0	3	C ₁₀ -----	NM	NM	-----
R ₂ -----	0	0	3	C ₁₁ -----	50	90	300
R ₃ -----	.2	.5	3	C ₁₂ -----	0	75	300
R ₄ -----	.2	.7	3	C ₁₃ -----	0	0	3
R ₅ -----	.1	0	3	C ₁₄ -----	0	0	3
R ₆ -----	15	90	300	C ₁₅ -----	0	0	3
R ₇ -----	.2	0	3	C ₁₆ -----	0	0	3
R ₈ -----	0	0	3	C ₁₇ -----	27	0	30
R ₉ -----	0	0	3	C ₁₈ -----	80	0	300
R ₁₀ -----	18	0	30	C ₁₉ -----	0	0	3
R ₁₁ -----	18	0	30	C ₂₀ -----	0	0	3
R ₁₂ -----	28	0	30	C ₂₁ -----	0	0	3
R ₁₃ -----	0	0	3	C ₂₂ -----	NM	NM	-----
R ₁₄ -----	0	0	3	C ₂₃ -----	.2	0	3
R ₁₅ -----	10	0	30	C ₂₄ -----	NM	NM	-----
R ₁₆ -----	65	0	300	C ₂₅ -----	.2	.2	3
R ₁₇ -----	45	0	300	C ₂₆ -----	.1	.1	3
R ₁₈ -----	15	15	30	C ₂₇ -----	NM	NM	-----
R ₁₉ -----	18	0	30	R ₂₅ -----	0.1	0	3
R ₂₀ -----	0	0	3	R ₂₆ -----	0	0	3
R ₂₁ -----	65	60	300	R ₂₇ -----	0	0	3
R ₂₂ -----	5	5	30	C ₁ -----	0	0	3
R ₂₃ -----	0	0	3	C ₂ -----	5	80	300
R ₂₄ -----	0	1	3	C ₃ -----	24	80	300
C ₄ -----	NM	NM	-----	C ₂₈ -----	85	80	300
C ₅ -----	.2	2	3	C ₂₉ -----	40	85	300
C ₆ -----	0	2	3	C ₃₀ -----	80	90	300
C ₇ -----	0	0	3	C ₃₁ -----	95	0	300
C ₈ -----	0	1.3	3	² L ₃ (L ₄)-----	0	10	30
C ₉ -----	NM	NM	-----				

All readings taken across component using the volt-ohmmeter of test set I-56-(*). Readings shown were taken using a 1000 ohm/volt meter. No d-c voltmeter readings should be taken where the letters NM appear in any column because of likely damage to the circuit. This is particularly true of d-c voltages reading across grid coupling capacitors.

¹ C₂₃ voltage will depend on bias connection.

² L₃ refers to SCR-535-A, and SCR-535-B. This component is marked L₄ in SCR-535-C.

CHART IV.—Average signal inputs for a fixed output (receiver)

NOTES

1. All values taken with chassis out of test case CS-81-(*).
2. A battery BA-37 voltage=1.45 volts.
3. B battery BA-38 voltage=100 volts.
4. Receiver earphone, or equivalent, connected across receiver output.

Signal generator connected to—	Signal generator frequency setting ¹	Dummy	Signal input to produce 20 volt output on V. T. V. ²	Signal input to produce 15 volt output on S. C. V. ³
Antenna.....	5205 kc	Through test stand FT-252-(*).	2.5 μ V.....	3 μ V.
Antenna (image frequency).	6115 kc	Through test stand FT-252-(*).	1850 μ V..	2250 μ V.
Antenna.....	455 kc.....	.1 μ f.....	20,000 μ V.	24,000 μ V.
R-f grid.....	5205 kc	.1 μ f.....	27 μ V.....	28 μ V.
Converter grid.....	455 kc	.1 μ f.....	190 μ V.....	200 μ V.
Converter grid.....	455 kc	.1 μ f.....	180 μ V.....	180 μ V.
I-f grid.....	455 kc	.1 μ f.....	2400 μ V.....	2400 μ V.
Microphone amplifier grid.	1000 cps	.1 μ f.....	.25 v.....	.275 v.
A-f output amplifier grid.	1000 cps	.1 μ f.....	1.1 v.....	1.3 v.

¹ Signal generator modulation—400 cps 30%.

² Values listed in this column are for 20-volt output reading on a general radio type 726-A vacuum-tube voltmeter.

³ Values listed in this column are for 15-volt output reading on 30-volt a-c range of selective analyzer of test set I-56-(*).

CHART V.—Average receiver performance characteristics

NOTE.—All values taken with chassis in test case CS-81-(*).

Test	Average		Minimum	
	Using V. T. V.	Using I-56-(*).	Using V. T. V.	Using I-56-(*).
Sensitivity.....	3 μ V ¹	4 μ V ²	6 μ V ¹	7 μ V ²
Image ratio.....	800	800	200	200.
Direct transmission ratio.	10,000	10,000	4,000	4,000.
Maximum audio output.	50 volts ¹	22 volts ²	40 volts ¹	18 volts. ²
A battery BA-37:				
Voltage.....	1.4 volts	1.4 volts		
Current.....	235 ma	235 ma	250 ma (max)	250 ma (max).
B battery BA-38:				
Voltage.....	103 volts	103 volts		
Current.....	11 ma	11 ma	14 ma (max).	14 ma (max).

¹ Readings made on a General Radio type 726-A vacuum tube voltmeter.

² Readings made on selective analyzer of test set I-56-(*).

³ 20-volt output meter reading. Signal generator modulation 400 cps 30%.

⁴ 15-volt output meter reading. Signal generator modulation 400 cps 30%.

SECTION V

SUPPLEMENTARY DATA

Paragraph

Table of replaceable parts—Radio receiver and transmitter BC-611-(*).----- 79

Names and addresses of manufacturers..... 80

Ref. No.	Signal Corps stock No.	Name of part	Description	Function	Mfr.	Galvan drag. No.
C ₁	3DA6-41	Capacitor	Fixed, paper, .006 μ f, \pm 20%, 100 v, part No. SB28514.	Voltage blocking, V ₁	(*)	---
C ₂	do	do	Fixed, paper, .0005 μ f, \pm 20%, 100 v, part No. SA28549. Part of N ₁ cup.	Screen grid bypass, V ₁	(*)	---
C ₃	do	do	Fixed, paper, .006 μ f, \pm 20%, 100 v, part No. SB28528. Part of N ₁ cup.	Plate bypass, V ₁	(*)	---
C ₄	3D9007-2	do	Fixed, ceramic, 7 μ f, \pm 5%, Type D, part No. 21A28815.	Grid neutralizing, V ₃	(*)	---
C ₅	do	do	Fixed, paper, .0005 μ f, \pm 20%, 100 v, part No. SB28528. Part of N ₁ cup.	Grid bias bypass, V ₃	(*)	---
C ₆	3D9025-36	do	Fixed, mica, 25 μ f, nominal, part No. 20A27459.	Oscillator feed-back	(*)	---
C ₇	3D9018V-4	do	Variable, mica, 18-160 μ f, part No. 20A27459.	Receiver antenna tuning	(*)	---
C ₈	3DA10-102	do	Fixed, paper, .01 μ f, \pm 20%, 100 v, part No. SA28550.	Filament bypass, V ₁	(*)	---
C ₉	3D9025-35	do	Fixed, ceramic, 25 μ f, \pm 10%, Type D, part No. 21A28816.	Coupling, V ₂ to V ₁ , transmitting.	1	---
C ₁₀	3D9015-18	do	Fixed, ceramic, 15 μ f, \pm 10%, Type D, part No. 21A28817.	Coupling, V ₁ to V ₂ , receiving.	1	---
C ₁₁	3DA100-120	do	Fixed, paper, .1 μ f, \pm 20%, 100 v, part No. SA29846.	Screen grid bypass, V ₂	(*)	---
C ₁₂	3D9007V-1	do	Variable, air, 7-140 μ f, part No. 19A25990.	Tuning, I ₁	(*)	---
C ₁₃	3DA10-6	do	Fixed, paper, .04 μ f, \pm 20%, 100 v, part No. SB28522.	Ave filter	(*)	---
C ₁₄	do	do	Fixed, paper, .01 μ f, \pm 20%, 100 v, part No. SB28530. Part of N ₂ cup.	Grid bias bypass, V ₂	(*)	---

C ₁₈	3D9058V	do	Variable, mica, 58 μ af, nominal, part No. 20A27340.	Tuning, L ₄ primary	(*)
C ₁₉	3D9058V	do	do	Tuning, I ₄ secondary	(*)
C ₂₀	3D9058V	do	Fixed, paper, .01 μ f, \pm 20%, 100 v, part No. 8B28530. Part of N ₃ cup.	Grid bias bypass, V ₃	(*)
C ₂₁	3D9028V	do	Fixed, paper, .01 μ f, \pm 20%, 100 v, part No. 8B28530. Part of N ₃ cup.	Plate bypass, V ₃	(*)
C ₂₂	3DA9070-6	do	Variable, mica, 28 μ af, nominal, part No. 20A28009.	Tuning, L ₅ secondary	(*)
C ₂₃	3DA9070-1	do	Fixed, mica, 70-100 μ af, nominal, part No. 20A28009.	Detector bypass	(*)
C ₂₄	3DA9007-1	do	do	do	(*)
C ₂₅	3DA6-41	do	Fixed, paper, .006 μ f, \pm 20%, 100 v, part No. 8A28544.	A f amplifier coupling	(*)
C ₂₆	3DA6-42	do	Fixed, paper, .006 μ f, \pm 20%, 100 v, part No. 8A28544.	do	(*)
C ₂₇	3DA20-43	do	Fixed, paper, .02 μ f, \pm 20%, 100 v, part No. 8B28528.	Grid bias bypass, V ₄	(*)
C ₂₈	3DA20-43	do	Fixed, paper, .02 μ f, \pm 20%, 100 v, part No. 8A30263.	Voltage blocking a-f output	(*)
C ₂₉	3DA20-43	do	Fixed, paper, .00025 μ f, \pm 20%, 100 v, part No. 8B28531. Part of N ₄ cup.	Plate bypass, V ₄	(*)
C ₃₀	3DA20-43	do	Fixed, paper, .01 μ f, \pm 20%, 100 v, part No. 8B28531. Part of N ₄ cup.	Screen grid bypass, V ₄	(*)
C ₃₁	3DA1-85	do	Fixed, paper, .006 μ f, \pm 20%, 100 v, part No. 8B28531. Part of N ₄ cup.	Coupling, V ₄ to V ₅	(*)
C ₃₂	3DA1-85	do	Fixed, paper, .001 μ f, \pm 20%, 100 v, part No. 8A28545.	Plate bypass, V ₆	(*)
C ₃₃	3DA75-1	do	Fixed, paper, .075 μ f, \pm 20%, 100 v, part No. 8A28546.	Screen grid bypass, V ₆	(*)
C ₃₄	3DA150-2	do	Fixed, paper, .13 μ f, \pm 20%, 100 v, part No. 8A29848.	Plate bypass, V ₆	(*)
C ₃₅	3DA150-2	do	Fixed, paper, .01 μ f, \pm 20%, 100 v, part No. 8B28530. Part of N ₃ cup.	Plate bypass, V ₄	(*)

*Diodes part made for or by Galvin Mfg. Corp., Chicago, Ill.

Radio receiver and transmitter BC-611-(*)—Continued

Ref. No.	Signal Corps stock No.	Name of part	Description	Function	Mfr.	Catalog draw. No.
L ₁	3C299-358	Coil C-358	Antenna, range 3500-3675 kc (for SCR-536-A).	Antenna loading	(*)	24B29012
L ₁	3C299-359	Coil C-359	Antenna, range 3675-3825 kc (for SCR-536-A).	do.	(*)	24B29012
L ₁	3C299-360	Coil C-360	Antenna, range 3825-4025 kc (for SCR-536-A).	do.	(*)	24B29012
L ₁	3C299-361	Coil C-361	Antenna, range 4025-4225 kc (for SCR-536-A).	do.	(*)	24B29012
L ₁	3C299-362	Coil C-362	Antenna, range 4225-4425 kc (for SCR-536-A).	do.	(*)	24B29012
L ₁	3C299-363	Coil C-363	Antenna, range 4425-4625 kc (for SCR-536-A).	do.	(*)	24B29012
L ₁	3C299-364	Coil C-364	Antenna, range 4625-4825 kc (for SCR-536-A).	do.	(*)	24B29012
L ₁	3C299-365	Coil C-365	Antenna, range 4825-5075 kc (for SCR-536-A).	do.	(*)	24B29012
L ₁	3C299-366	Coil C-366	Antenna, range 5075-5300 kc (for SCR-536-A).	do.	(*)	24B29012
L ₁	3C299-367	Coil C-367	Antenna, range 5300-5500 kc (for SCR-536-A).	do.	(*)	24B29012
L ₁	3C299-368	Coil C-368	Antenna, range 5500-5775 kc (for SCR-536-A).	do.	(*)	24B29012
L ₁	3C299-369	Coil C-369	Antenna, range 5775-6000 kc (for SCR-536-A).	do.	(*)	24B29012
L ₁	3C299-361	Coil C-361	Antenna, frequency 4035 kc, part No. 24K34970 (for SCR-536-B and C).	do.	(*)	24B29012
L ₁	3C299-363	Coil C-363	Antenna, frequency 4495 kc, part No. 24K34971 (for SCR-536-B and C).	do.	(*)	24B29012
L ₁	3C299-365	Coil C-365	Antenna, frequency 4930 kc, part No. 24K34972 (for SCR-536-B and C).	do.	(*)	24B29012

I ₁	3C299-366.....	Coil C-366.....	Antenna, frequency 5205 kc, part No. 24K34973 (for SCR-536-B and C).do.....	(*)	24B29012
L ₁	3C299-367.....	Coil C-367.....	Antenna, frequency 5397.5 kc, part No. 24K34974 (for SCR-536-B and C).do.....	(*)	24B29012
L ₁	3C299-368.....	Coil C-368.....	Antenna, frequency 5500 kc, part No. 24K34975 (for SCR-536-B and C).do.....	(*)	24B29012
I ₂	3C299-370.....	Coil C-370.....	R-f tank, range 3500-3825 kc (for SCR-536-A).	R-f amplifier loading.....	(*)	24A29061
I ₂	3C299-371.....	Coil C-371.....	R-f tank, range 3825-4225 kc (for SCR-536-A).do.....	(*)	24A29062
I ₂	3C299-372.....	Coil C-372.....	R-f tank, range 4225-4625 kc (for SCR-538-A).do.....	(*)	24A29063
I ₂	3C299-373.....	Coil C-373.....	R-f tank, range 4625-5075 kc (for SCR-536-A).do.....	(*)	24A29064
I ₂	3C299-374.....	Coil C-374.....	R-f tank, range 5075-5500 kc (for SCR-536-A).do.....	(*)	24A29065
I ₂	3C299-375.....	Coil C-375.....	R-f tank, range 5500-6000 kc (for SCR-536-A).do.....	(*)	24A29052
I ₂	3C299-371.....	Coil C-371.....	R-f tank, frequency 4035 kc, part No. 24B35222 (for SCR-536-B and C).do.....	(*)	24B35222
I ₂	3C299-372.....	Coil C-372.....	R-f tank, frequency 4495 kc, part No. 24K35223 (for SCR-536-B and C).do.....	(*)	24B35222
L ₁	3C299-373.....	Coil C-373.....	R-f tank, frequency 4930 kc, part No. 24K35224 (for SCR-536-B and C).do.....	(*)	24B35222
L ₁	3C299-374.....	Coil C-374.....	R-f tank, frequency 5205 kc, part No. 24K35225 (for SCR-536-B and C).do.....	(*)	24B35222
L ₁	3C299-374.....	do.....	R-f tank, frequency 5397.5 kc, part No. 24K35226 (for SCR-536-B and C).do.....	(*)	24B35222
L ₁	3C299-357.....	Coil C-357.....	R-f tank, frequency 5500 kc, part No. 24K35227 (for SCR-536-B and C).do.....	(*)	24B35222

*Denotes part made for or by Galvin Mfg. Corp., Chicago, Ill.

Radio receiver and transmitter BC-611-(*)—Continued

Ref. No.	Signal Corps stock No.	Name of part	Description	Function	Mfr.	Calvin dwg. No.
L ₆	3C362-17	Coil	R-f choke; .5 mh, part No. 24A28595.	Oscillator, V ₁	(*)	
T ₁ (L ₄)	2C5351A/A4	do.	I-f input transformer and shield, part No. 1B28670.	Coupling V ₂ -V ₃	(*)	
T ₁ (L ₅)	2C5351A/A5	do.	I-f output transformer and shield, part No. 1B28668.	Coupling, V ₃ -V ₄	(*)	
L ₄ (L ₅)	3C362-16	do.	Audio output reactor; 590-850 ohms d-c resistance, part No. 25A28551.	Output plate load	(*)	
M ₁	2Z3543-50	Crystal	Receiver crystal (Specify frequency), part No. 48K28681.	Receiver stability control.	(*)	48B27212
M ₂	2Z3543-50	do.	Transmitter crystal (Specify frequency).	Transmitter frequency control.	(*)	48B27212
M ₃	3Z8318	Switch	Change-over switch, eight-pole, double throw, part No. 40B25825.	Send-receive	(*)	
M ₄	2C5351A/A3	Microphone	Microphone and leads assembly, dynamic, part No. 1X31098.	Transmission	(*)	
M ₄	2C5351A/A3	do.	Microphone and leads assembly, crystal (Early issue of SCR-536-A).	do.	(*)	
M ₄	2C5351A/A2	Earphone	Earphone and leads assembly, dynamic, part No. 1X31094.	Receiving	(*)	
M ₄	2C5351A/A2	do.	Earphone and leads assembly, crystal (Early issue of SCR-536-A).	do.	(*)	
M ₆	3Z9853	Switch	Toggle, DPST, part No. 40A25820.	Filament and plate power supply.	(*)	
M ₇	3A38	Battery	103.5 volts, Type RA-38, B, part No. 48B25848.	Plate power supply	(*)	
M ₈	3A37	do.	1½ volt, Type BA-37-A, part No. 48B27576.	Filament power supply	(*)	
M ₉	2Z11100.1	Tube shield	Metal shield, part No. 26A27204.	VT-174 shield	(*)	
M ₁₀	2Z11100.1	do.	do.	VT-171 shield	(*)	
M ₁₁	2Z11100.1	do.	do.	VT-173 shield	(*)	

M ₁₂	2A292-2	Antenna	4-section collapsible antenna assembly, part No. 1C28682. Contains C ₁ , C ₂ , C _{2a} , R ₃ and R ₄ , part No. 8B28528.	Radiator for transmitter; antenna for receiver.	(*)
N ₁	2C5351A/C4	Capacitor-resistor cup (VT-174).	Contains C ₃ , C _{3a} , C _{3b} , R ₅ and R _{5a} , part No. 8B28528.	Capacitor-resistor container.	(*)
N ₂	2C5351A/C5	Capacitor-resistor cup (VT-171).	Contains C ₃ , C _{3a} , and R ₅ , part No. 8B28529.	do.	(*)
N ₃	2C5351A/C3	Capacitor-resistor cup (VT-173).	Contains C ₄ , C _{4a} , C ₅ , C _{5a} , R ₁₂ and R _{12a} , part No. 8B28530.	Capacitor-resistor container.	(*)
N ₄	2C5351A/C2	Capacitor-resistor cup (VT-172).	Contains C ₂ , C _{2a} , C _{2b} , R ₆ , R _{6a} , R _{6b} and R _{6c} , part No. 8B28531.	Capacitor-resistor container.	(*)
R ₁		Resistor	Fixed, carbon, 1 megohm, ±10%, ½ watt, not insulated, part No. 8B28529.	Converter grid, V ₂	(*)
R ₂	3Z6801 24	do.	Part of N ₂ cup. Fixed, carbon, 1 megohm, ±10%, ½ watt, insulated, type MB ½ INS, part No. 6B6337.	Grid bias, V ₂	4
R ₃	do.	do.	Fixed, carbon, 56,000 ohms, ±10%, ¼ watt, not insulated, part No. 8B28528.	Oscillator grid bias, V ₁	(*)
R ₄	do.	do.	Part of N ₁ cup. Fixed, carbon, 33,000 ohms, ±10%, ¼ watt, not insulated, part No. 8B28528.	Oscillator grid bias, V ₂	(*)
R ₅	3Z6330 4	do.	Part of N ₁ cup. Fixed, carbon, 3,300 ohms, ±10%, ¼ watt, insulated, type MB ½ INS, part No. 6B6379.	Sensitivity control	4
R ₆	3Z6747-6	do.	Fixed, carbon, 470,000 ohms, ±10%, ¼ watt, insulated, type MB ½ INS, part No. 6B6338.	Grid bias, V ₁	4
R ₇	3Z6470-0	do.	Fixed, carbon, 4,700 ohms, ±10%, ¼ watt, insulated, type MB ½ INS, part No. 6B6351.	Sensitivity control	4
R ₈	3Z6801 23	do.	Fixed, carbon, 1 megohm, ±10%, ¼ watt, not insulated, type 997-A, part No. 6B5594.	Load, T ₁ (L ₄) secondary	3

1 Reference numbers in parentheses are for SCR-596-A and SCR-596-B.

2 These reference numbers do not appear on parts in illustrations nor in references to parts throughout this manual.

* Denotes part made for or by Galvut Mfg. Corp., Chicago, Ill.

Radio receiver and transmitter BC-611-(*)—Continued

Ref. No.	Signal Corps stock No.	Name of part	Description	Function	Mfr.	Galvin drwg. No.
R ₄	3Z804A7-2	Resistor	Fixed, carbon, 4.7 megohm, $\pm 10\%$, $\frac{1}{2}$ watt, not insulated, part No. 8B28531.	Avc filter	(*)	---
R ₁₀	3Z0647-5	do	Fixed, carbon, 47,000 ohms, $\pm 10\%$, $\frac{1}{4}$ watt, insulated, type MB $\frac{1}{2}$ INS, part No. 6B6323.	Plate dropping, V ₁	4	---
R ₁₁	3Z6633-3	do	Fixed, carbon, 33,000 ohms, $\pm 10\%$, $\frac{1}{4}$ watt, insulated, type MB $\frac{1}{2}$ INS, part No. 6B6448.	Plate dropping, V ₅	4	---
R ₁₂	---	do	Fixed, carbon, 68,000 ohms, $\pm 10\%$, $\frac{1}{4}$ watt, not insulated, part No. 8B28530. Part of N ₃ cup.	Screen grid dropping V ₂	(*)	---
R ₁₃	3Z6722-4	do	Fixed, carbon, 220,000 ohms, $\pm 10\%$, $\frac{1}{2}$ watt, not insulated, type 997-A, part No. 6B5571.	Detector filter, V ₄	3	---
R ₁₄	---	do	Fixed, carbon, 1 megohm, $\pm 10\%$, $\frac{1}{2}$ watt, not insulated, part No. 8B28531. Part of N ₄ cup.	Detector load, V ₄	(*)	---
R ₁₅	---	do	Fixed, carbon, 6,800 ohms, $\pm 10\%$, $\frac{1}{4}$ watt, not insulated, part No. 8B28530. Part of N ₄ cup.	Plate dropping, V ₃	(*)	---
R ₁₆	3Z6733-2	do	Fixed, carbon, 330,000 ohms, $\pm 10\%$, $\frac{1}{2}$ watt, insulated, type MB $\frac{1}{2}$ INS, part No. 6B6366.	Screen grid dropping, V ₃	4	---
R ₁₇	3Z6627-7	do	Fixed, carbon, 22,000 ohms, $\pm 10\%$, $\frac{1}{4}$ watt, insulated, type MB $\frac{1}{2}$ INS, part No. 6B6370.	Screen grid dropping, V ₃	4	---
R ₁₈	3Z6722-9	do	Fixed, carbon, 220,000 ohms, $\pm 10\%$, $\frac{1}{2}$ watt, insulated, type MB $\frac{1}{2}$ INS, part No. 6B6349.	Screen grid dropping, V ₁	4	---

R ₁	3Z0709-3	do	Fixed, carbon, 680,000 ohms, ± 10%, ½ watt, insulated, type MB ½ INS, part No. 6B6388.	4	Plate dropping, V _a -----
R ₂	3Z6810-6	do	Fixed, carbon, 10 megohm, ± 10%, ½ watt, insulated, type EB INS, part No. 6B5572.	2	Grid Bias, V _a -----
R ₃		do	Fixed, carbon, 3.3 megohm, ± 10%, ¼ watt, not insulated, part No. 8B28531. Part of N ₁ cup.	(*)	Screen grid dropping, V _a -----
R ₄		do	Fixed, carbon, 1 megohm, ± 10%, ¼ watt, not insulated, part No. 8B28531. Part of N ₁ cup.	(*)	Plate load, V _a -----
R ₅	3Z6802A3-1	do	Fixed, carbon, 3.3 megohm, ± 10%, ¼ watt, insulated, type MB ½ INS, part No. 6B6364.	4	Grid bias, V _a -----
R ₆	3Z6390	do	Fixed, carbon, 3,900 ohms, ± 10%, ¼ watt, insulated, type MB ½ INS, part No. 6B5573.	4	Screen grid decoupling, V _a -----
R ₇	3Z6568-9	do	Fixed, carbon, 6,800 ohms, ± 10%, ¼ watt, insulated, type MB ½ INS, part No. 6B6350.	4	Sensitivity control
R ₈	3Z6804A7-1	do	Fixed, carbon, 4.7 megohm, ± 10%, ¼ watt, insulated, type EB INS, part No. 6B6391.	2	Avc filter-----
R ₉	3Z6747-6	do	Fixed, carbon, 470,000 ohms, ± 10%, ¼ watt, insulated, type MB ½ INS, part No. 6B6388.	4	Damping-----
	3Z8318/L1	Arm, switch lever (long).	Metal, 2" long, ¼" wide, part No. 45B27215.	(*)	Part of push-to-talk switch lever assembly.
	3Z8318/L2	Arm, switch lever (short).	Metal, 1 ¾" long, ¼" wide, part No. 45A25898.	(*)	do-----
	2S536A/A1	Assembly, antenna cap and chain.	Aluminum cap, ¼" diameter, 3 ¾" high beaded chain 4" long, part No. 1X28690.	(*)	Cover for antenna-----
	2C5351A/A6	Assembly, bracket and grommet.	Aluminum, ¾" x ½", ¼" hole with rubber grommet, part No. 1X30139.	(*)	Holds VT-172 and VT-174 in socket.

*Denotes part made for or by Galvin Mfg. Corp., Chicago, Ill.

Radio receiver and transmitter BC-611-(*)—Continued

Ref. No.	Signal Corps stock No.	Name of part	Description	Function	Mfr.	Drawn draw. No.
100	2S536A/A3	Assembly, bottom cover.	Metal, 3 $\frac{3}{8}$ " x 3 $\frac{3}{8}$ ", complete with battery contactor plate and springs, part No. 1X28692.	Bottom cover of housing and battery contactor.	(*)	
101	2C536A/A3/3	Assembly, and plate.	Bakelite, 3 $\frac{3}{4}$ " x 1 $\frac{1}{2}$ " complete with terminals and contacts part No. 1X28667.	End plate of chassis	(*)	
102	2C536A/A3/4	Assembly, filler and clips.	Fiber, 1 $\frac{1}{4}$ " wide, 11 $\frac{1}{2}$ " long, clip riveted on each end, part No. 1X29056.	Used to fill space between battery BA-38 and housing.	(*)	
103	2S536A/A3/1	Assembly, spade bolt and cover.	$\frac{3}{8}$ " spade bolt with $\frac{5}{8}$ " diameter, knurled edge nut, part No. 1X29661.	Holds bottom cover shut.	(*)	
104	2S536A/A2	Assembly, strap.	Olive drab strap, 1 $\frac{1}{4}$ " wide, 30" long, part No. 1X28691.	Carrying strap.	(*)	
105	2S536A/A4	Assembly, top cover.	Aluminum, 3 $\frac{3}{4}$ " x 3 $\frac{3}{4}$ " complete with battery spacer and springs, antenna insulator, moisture seal and strap hanger, part No. 1X28688.	Top cover of housing.	(*)	
106	2A292-2/3	Ball end, antenna.	Marblette ball, $\frac{1}{2}$ " diameter, olive drab finish, part No. 67A27209.	On tip of antenna to aid in pulling antenna out.		
107	2C535A/A/2/2	Bezel, data plate.	Aluminum frame 2 $\frac{1}{4}$ " x $\frac{3}{4}$ ", part No. 13A28571.	Frame for data plate.	(*)	
108	3Z8318/B1	Bracket, switch stop.	Metal $\frac{3}{8}$ " x $\frac{5}{8}$ ", with a .144" diameter hole, part No. 7A31332.	Part of push-to-talk switch, lever top.	(*)	
109	2Z11100.1/1	Bracket, tube retainer.	Aluminum, $\frac{1}{4}$ " x $\frac{1}{2}$ " with $\frac{5}{16}$ " hole, part No. 7A25988.	Holds tube shield for VT-174, VT-171, and VT-173.	(*)	
110	2C5351A/A2/1	Cap, phone, and microphone.	Molded bakelite, 2 $\frac{5}{8}$ " diameter, part No. 67B25832.	Cap for mouthpiece and carpiece.	(*)	
111	2Z2626.3	Clamp, capacitor.	Brass, semicircular, $\frac{1}{8}$ " radius, part No. 42A28454.	Holds capacitor Cap.	(*)	

112	2Z2645	Clamp, crystal	Phosphor bronze $\frac{5}{16}$ " wide "L" shaped, part No. 42A28543.	Holds crystals	(*)
113	2C5351A/J2/1	Cover, data plate	Clear vinylite, $1\frac{1}{2}$ " x $\frac{1}{16}$ ", part No. 61A28436.	Transparent cover for data plate.	(*)
114	2Z3401.1	Cover r-f choke	Bakelite, $1\frac{1}{2}$ " long, $\frac{1}{2}$ " outside diameter, part No. 67A30885.	Cover for r-f choke L ₄ .	(*)
115	3Z8318/C2	Cover, switch	Acetate celluloid, $1\frac{1}{2}$ " x $10\frac{1}{4}$ ", part No. 61B28450.	Cover for change-over switch assembly.	(*)
116	3Z8318/C1	Cover, switch mechanism	Molded rubber, $1\frac{1}{2}$ " x 4", part No. 37C27218.	Cover for push-to-talk switch assembly.	(*)
117	3Z8318/F1	Frame, cover clamping	Aluminum frame $1\frac{1}{2}$ " x 4" with 6 holes $.156$ " diameter for mounting, part No. 42B25987.	Frame for push-to-talk switch cover.	(*)
118	3Z8318/M1	Pulverum, hinge	Alcoa metal, one $.156$ " hole for mounting $.067$ ", hole for hinge pin, part No. 45A27219.	Part of push-to-talk switch assembly.	(*)
119	2A292-2/4	Guide, antenna	Molded $7\frac{1}{2}$ " long, $.282$ " diameter groove, part No. 67B27214.	Guide for antenna.	(*)
120	2C5351A/J2.1	Housing	Housing, less all parts, $11\frac{1}{2}$ " x $3\frac{3}{8}$ " x $3\frac{3}{8}$ ", part No. 62D27227.	Housing for unit.	(*)
121	3Z8318/L3	Link, sliding hinge	Metal, $1\frac{1}{2}$ " x $\frac{3}{16}$ ", slotted, hole at end for hinge pin, part No. 45B27221.	Part of push-to-talk switch assembly.	(*)
122	No number to be assigned.	Nameplate	Vinylite, $1\frac{1}{2}$ " x $3\frac{1}{2}$ ", black background, part No. 13K34050.	Model, order and serial number data plate.	(*)
123	2C5351A/N1	Nut, chamfered	Brass, nickel plated, $\frac{5}{16}$ " x $\frac{1}{8}$ ", part No. 2A30408.	Tank capacitor mounting.	(*)
124	2S5351A/A3/2	Pin, groove	$\frac{1}{2}$ " long, $.093$ " diameter, metal, part No. 47A28460.	Hinge pin for mounting spade bolt and nut.	(*)
125	3Z8318/P1	Pin, hinge	$\frac{5}{8}$ " long, 0.125 " diameter, 4-36 thread on one end, part No. 47A25997.	Part of push-to-talk switch; holds long and short levers together.	(*)
126	3Z8318/P2	do.	0.672 " long x 0.062 " diameter, part No. 47A25999.	Part of push-to-talk switch assembly.	(*)
127	2C5351A/J2/4	Plate, data	Vinylite plate, $1\frac{1}{2}$ " x $1\frac{1}{2}$ " part No. 13A28455.	Frequency, channel and battery date information plate.	(*)

*These reference numbers do not appear on parts in illustrations nor in reference to parts throughout this manual.

*Denotes part made for or by Galvin Mfg. Corp., Chicago, Ill.

Radio receiver and transmitter BC-611-(*)—Continued

Ref. No.	Signal Corps stock No.	Name of part	Description	Function	Mfr.	Galvin drawg. No.
128	2C5351A/S1	Plug, jumper	Molded bakelite over wire jumper, $\frac{1}{16}'' \times \frac{1}{8}''$, part No. 28A28535.	Jumper for plate meter terminals when meter is not used.		
129	2S536A/A2/3	Rod, housing and strap support (long)	2" long, $\frac{1}{32}''$ diameter, threaded at one end, part No. 46K27220.	Bottom cover hinge rod and strap support.		
130	2S536A/A2/2	Rod, housing and strap support (short)	1 $\frac{1}{2}''$ long, $\frac{1}{32}''$ diameter, threaded at one end, part No. 46A25849.	Top cover hinge rod and strap hanger support.		
131	2S536A/A4/1	Seal, moisture	Rubber, $\frac{1}{16}''$ diameter, $\frac{1}{4}''$ hole, part No. 37A27308.	Weatherproofing at antenna through top cover.		
132	2S530A/A3/5	Seal, rubber ring	Sponge rubber ring, $\frac{1}{8}'' \times \frac{3}{16}'' \times \frac{3}{16}''$, part No. 37A25986.	Top and bottom cover rubber seal.		
133	2Z8761-10	Socket, crystal	2-crystal receptacle, part No. 9A25981.	Socket for two crystals.	(*)	
134	2C5351A/S1	Spring, coil retainer	Phosphor bronze, $\frac{3}{8}'' \times \frac{1}{4}''$ with .127" diameter hole for mounting, part No. 41A25995.	Tank coil retainer spring.	(*)	
135	3Z8318/S2	Spring, cushion	Phosphor bronze, $\frac{3}{8}'' \times \frac{3}{8}''$ spring, part No. 41A28432.	Part of push-to-talk switch assembly.	(*)	
136	3Z8318/S1	Spring, switch lever	Stainless steel spring, part No. 41A27203.	Lever return spring, part of push-to-talk switch assembly.	(*)	
137	2Z8669-6	Tube socket	7 prong miniature	VT-171, VT-172, VT-173, tube socket.	(*)	9A6794
138	2Z8669-6	do	6 prong miniature, part No. 9K6796.	VT-174 tube socket.	(*)	9A6794

† These reference numbers do not appear on parts in illustrations not in reference to parts throughout this manual.

* Denotes part made for or by Galvin Mfg. Corp., Chicago, Ill.

80. Names and addresses of manufacturers.

Mfr. No.	Name	Street address	City	State
1	Centralab.....	900 E. Keefe Ave.	Milwaukee.....	Wisconsin.
2	Allen Bradley Co.....	Milwaukee.....	Wisconsin.
3	Carborundum Corp..	Globar Division.	Niagara Falls....	New York.
4	Stackpole Carbon Co..	Elk County....	St. Mary's.....	Pennsylvania.

INDEX

	Paragraphs	Pages
Adjustments:		
Alinement.....	62, 74	40, 54
Presetting.....	58, 59, 72, 73	33, 36, 50, 51
Antenna coil:		
Replacement.....	55, 70	29, 44
Tuning.....	58, 72	33, 50
Batteries:		
Installation.....	11	6
Life.....	4	3
Testing.....	63	40
Type used.....	4	3
Bias, adjustment.....	78	64
Change of frequency.....	54, 69	28, 43
Change-over switch:		
Adjustment.....	78	64
Functioning.....	37	18
Coils:		
Frequency range of (chart I).....	70	44
Replacement.....	55, 70	29, 44
Components:		
Description.....	9	5
Weights and dimensions.....	2	3
Controls:		
Location.....	8	5
Operation.....	13, 16	7, 9
Power switch.....	13	7
Push-to-talk switch.....	15	8
Crystal activity test.....	57	33
Crystal earphone.....	9	5
Crystal microphone.....	9	5
Crystals, replacement of.....	55, 70	29, 44
Current readings:		
Receiving.....	58	33
Transmission.....	59	36
Description of components.....	9	5
Difference between SCR-536-A, B, and C.....	1	2
Dimensions of components.....	2	3
Distance range.....	5	4
Earphone:		
Crystal.....	9	5
Inductor.....	9	5
Employment.....	10	6
Frequency coverage.....	6	4
Frequency presetting.....	54, 69	28, 43
Functioning of parts.....	24-38	11

INDEX

	Paragraphs	Pages
I-f amplifier:		
Alinement.....	62, 74	40, 54
Functioning.....	28	14
Input power.....	4	3
Locating trouble.....	23, 47, 48, 78	10, 23, 64
Manufacturers' addresses.....	80	81
Measurements, voltage (chart III).		
Microphone—		
Amplifier, circuit.....	35	17
Crystal.....	9	5
Inductor.....	9	5
Modes of transmission and reception.....	7	5
Modulation:		
Percentage.....	59, 73	36, 51
Circuit.....	36	17
Netting.....	18	9
Operation.....	13	7
Oscillator, circuit.....	33	17
Parts:		
List of replaceable.....	79	70
Replacement.....	55, 70, 77	29, 44, 60
Poor reception and transmission.....	23, 47	10, 23
Power amplifier:		
Circuit.....	34	17
Tuning.....	58, 73	33, 51
Preparation for use.....	12	7
Presetting receiver with IE-15-A.....	72	50
Presetting receiver with IE-17-(*).....	58	33
Presetting transmitter with IE-15-A.....	73	51
Presetting transmitter with IE-17-(*).....	59	36
Procedure in locating trouble.....	23, 47, 48, 78	10, 23, 64
Rain, operation in.....	22	10
Receiver:		
Alinement.....	62, 74	40, 54
Characteristics (chart V)		
Functioning.....	24	11
Presetting.....	55-58, 69-72	29, 43
Sensitivity.....	78	64
Receiving.....	14	8
Removal of eyelet.....	77	60
Repairs.....	39, 77, 78	22, 60, 64
Replacement of—		
Antenna coil.....	55, 70	29, 44
Batteries.....	11	6
Crystals.....	55, 70	29, 44
Earphone.....	45	23
I-f transformer.....	77	60
Microphone.....	44	23
Power switch.....	77	60
R-f tank coil.....	55, 70	29, 44
Resistor-capacitor cups.....	77	60

INDEX

	Paragraphs	Pages
Setting up test equipment IE-15-A.....	71	45
Setting up test equipment IE-17-(*).....	56	32
Starting set.....	13	7
Switch, change-over:		
Adjustment.....	78	64
Function.....	37	18
Operation.....	15	8
Test case CS-81-(*).....	50, 51, 64, 65	24, 42
Test equipment IE-15-A.....	64	42
Test equipment IE-15-A, presetting with.....	69	43
Test equipment IE-17-(*).....	50	24
Test equipment IE-17-(*), presetting with.....	54	28
Test harness.....	67	43
Test set I-56-(*).....	68	43
Test stand FT-252-(*).....	50, 52, 64, 66	24, 42
Test unit I-135-(*).....	50, 53, 56, 62, 63	24,
		25, 32, 40
Testing batteries.....	63	40
Total weight.....	3	3
Transmitter:		
Characteristics (chart II).....	78	64
Circuit.....	31, 32	15
Presetting.....	55, 56, 57, 59, 70, 71, 73	29,
		32, 33, 36,
		44, 45, 51
Transmitting.....	15	8
Trouble, location.....	23, 47, 48, 78	10, 23, 64
Tubes, vacuum:		
Base connections (fig. 24).....	77	60
Replacement.....	41	23
Vacuum tube base connections (fig. 24).....	77	60
Vacuum tubes, replacement of.....	41	23
Voltage measurements (fig. 25 and chart III).....	78	64
Weak signals, cause of.....	47	23
Weights:		
Components.....	2	3
Total.....	3	3

[A. G. 062.11 (1-29-43).]

BY ORDER OF THE SECRETARY OF WAR:

G. C. MARSHALL,
Chief of Staff.

OFFICIAL:

J. A. ULIO,
Major General,
The Adjutant General.

DISTRIBUTION:

B 5 (2); R 7 (3); Bn 7 (5); I Bn 5, 44 (5); IC 5 (10), 4, 7, 44,
(5) and 11 (4).

(For explanation of symbols see FM 21-6.)

22.1. (Added.) Operation in freezing weather and dust.—

a. When the set is used in freezing weather, moisture from the breath condenses and freezes, plugging the holes in the microphone cap and making transmission impossible. This freezing condition can be prevented by the use of microphone cover M-367 which also serves as protection against sand or dust.

b. The cover is made of a light, water-repellent fabric with a draw-string or elastic band for holding it tightly over the microphone on the set. The cover is not waterproof and will not protect against immersion in water or against long exposure to tropical humidity.

c. Microphone cover M-367 will be used whenever the radio set is operated under freezing, dusty, or sandy conditions.

d. All organizations will requisition one microphone cover M-367, stock No. 2B1567, for each radio set SCR-536-(*) on hand, if the set is not already provided with the cover. OCSlgO Supply Letter No. 173, 10 August 1943, authorizes this requisition.

e. New issues of radio sets SCR-536-(*) will be supplied with the cover as a component part.

* * * * *

[A. G. 300.7 (20 Nov 43).] (C 1, 15 Dec 43.)

33. Oscillator.

* * * * *

c. (Added.) In radio receiver and transmitter BC-611-D and late models of BC-611-C, resistor R_{28} is added in series with the screen circuit of V_2 (VT-171). R_{28} reduces the screen voltage in the *transmit* position to eliminate the possibility of oscillator failure when using a tube VT-171 having low emission.

[A. G. 300.7 (20 Nov 43).] (C 1, 15 Dec 43.)

37. Change-over switch.

* * * * *

l. Sections *L* and * * * *L* and *M*. In radio receiver and transmitter BC-611-D and late models of BC-611-C, resistor R_{28} is placed in series with the screen of V_2 in the *transmit* position.

* * * * *

[A. G. 300.7 (20 Nov 43).] (C 1, 15 Dec 43.)

TL-5571-B

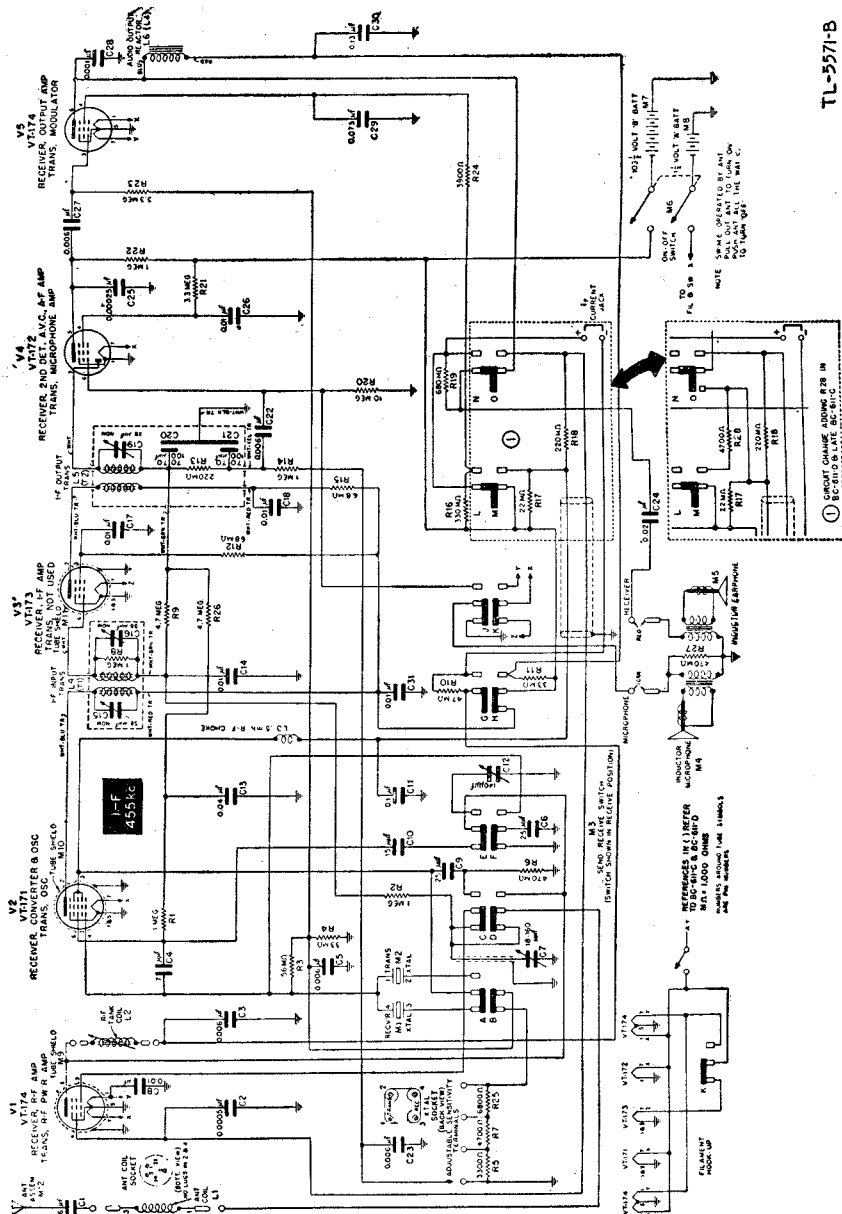

FIGURE 17.—Radio receiver and transmitter BC-611-B, BC-611-C, and BC-611-D—schematic diagram.

[A. G. 300.7 (20 Nov 43).] (C 1, 15 Dec 43.)

78. Trouble location and remedy.

CHART II.—Chart of average transmitter performance characteristics

Test	Average	Minimum
R-f current: Unmodulated.....	18 ma (r-f power: 181 mw)	15 ma (r-f power: 126 mw).
Modulated.....	20.5 ma (r-f power: 255.3 mw).	17.5 ma (r-f power: 170 mw).

CHART III.—Point-to-point d-c voltage measurements

Component	Receiver	Transmitter	Voltmeter range	Component	Receiver	Transmitter	Voltmeter range
R ₁₇	45	(5) 30	300	C ₂₁1	.1	3

* Refers to SCR-536-D and late models of SCR-536-C.

[A. G. 300.7 (20 Nov 43).] (C 1, 15 Dec 43.)

79. Table of replaceable parts.—Radio receiver and transmitter BC-611-(³).

Ref. No.	Signal Corps stock No.	Name of part	Description	Function	Mfr.	Galvin drawg. No.
R ₂₇ R ₂₈	3Z6470-9	Resistor.....	Fixed carbon, 4,700 ohms, 10%, 1/3 watt, insulated, type MBI/3 INS, part No. 6B6351.	Screen grid dropping, V ₂ .	4	
113 113 ³ / ₂	2B1567	Cover, microphone.	Light, water-repellent fabric with drawstring or elastic band.	Protect microphone.		

[A. G. 300.7 (20 Nov 43).] (C 1, 15 Dec 43.)

BY ORDER OF THE SECRETARY OF WAR:

OFFICIAL:

J. A. ULIO,
Major General,
The Adjutant General.

G. C. MARSHALL,
Chief of Staff.